

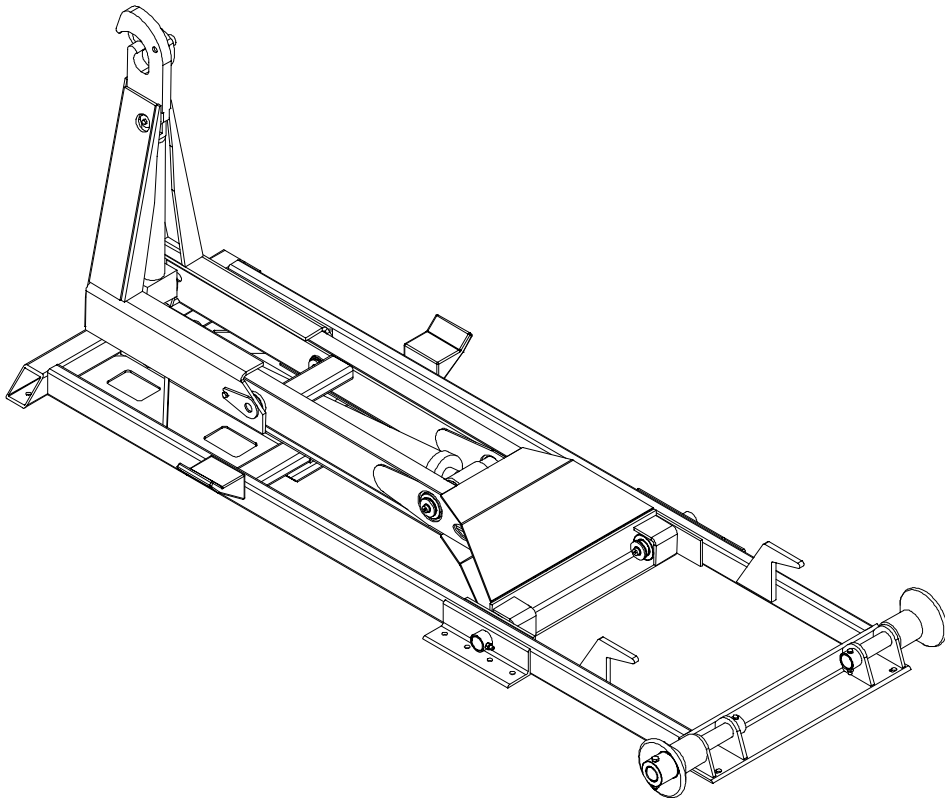

***STELLAR SHUTTLE***  
***MODEL 84-12-13 H***  
***P/N (5937)***  
***ASSEMBLY***  
***AND***  
***INSTALLATION***  
***MANUAL***



## Table of Contents

Hydraulic Hook Lift Specifications.....	2
Base Assembly.....	3
Secondary Assembly.....	4
Tilt Assembly.....	5
Installation Instructions.....	6
Mounting Kit.....	7
Safety Valve Installation.....	8
Hydraulic Assembly.....	9
10 gal Tank Assembly.....	10
Hose Kit.....	11
Controller Assembly.....	12
Subframe.....	13
Warranty.....	14

## Hydraulic Hook Lift Specifications

<b>Lifting Capacity:</b>	13,000 pounds gross weight evenly distributed in, or on, body.
<b>Container Length:</b>	10-foot through 13-foot from front A-frame to rear of skid rails. Longer bodies may be accommodated if full dump angle is not required (may require special body-mounted or extendable truck-mounted bumper to meet the Office of Motor Carrier Safety (OMCS) Rear End Protection regulation 393.86)
<b>Maximum Dump Angle:</b>	43° with a 10-foot body and 38° with a 13-foot body
<b>Operating Pressure:</b>	4200 PSI maximum
<b>Weight of Loader:</b>	Loader weight not to exceed 1,500 pounds
<b>Height of Loader:</b>	Loader height not to exceed 5 1/2" as measured from top of truck frame to top of loader rollers
<b>Hook Height:</b>	35.63-inches from bottom of skid rails to bottom of hook bar. Loader must be able to pick up 10-inches below grade when mounted on a truck with 36" frame height.
<b>Hydraulic Pump:</b>	Direct-coupled high-pressure gear pump.
<b>Hydraulic Control Valve:</b>	Stack-type valve mounted directed onto the oil reservoir.
<b>Controls:</b>	Dual manual levers with sealed cable actuators mounted in the truck cab to allow full feathering of all loader functions.
<b>Tilting Hook Assembly:</b>	Loader must have pivoting type front tilt section (jib) to provide a low degree loading/unloading angle. Hook to include automatic mechanical safety latch, which disengages only when the container/body is in proper position to be picked up or dropped off.
<b>Tilt Cylinder:</b>	Single 3-inch bore with 1-1/2-inch diameter rod cylinder. Cylinder must be double acting and include dual integral pilot-operated counterbalance valves to prevent cylinder collapse in case of hose failure.
<b>Lift/Dump Cylinder:</b>	Single 5-inch bore with 2-inch diameter rod cylinder. Cylinder must be double acting and include dual integral pilot-operated counterbalance valves to prevent cylinder collapse in case of hose failure.
<b>Rear Body Hold-Downs:</b>	Dual fixed-position hold-down devices mounted to the dump frame to secure the body to the loader through all ranges of the dump mode. This must be accomplished without the use of steel springs and/or hydraulic/air cylinders.
<b>Pins &amp; Bushings</b>	All pins to be hardened chrome steel. All bushings to be of the permanently lubricated variety. No grease zerks allowed.
<b>Hoses &amp; Hydraulic Fittings:</b>	All hoses and fittings are to be SAE: metrics not allowed. O-ring face seal fittings to be utilized wherever possible.
<b>Origin of Manufacture:</b>	Loader to be designed and manufactured in the United States of America.

## Base Assembly P/N (17970)

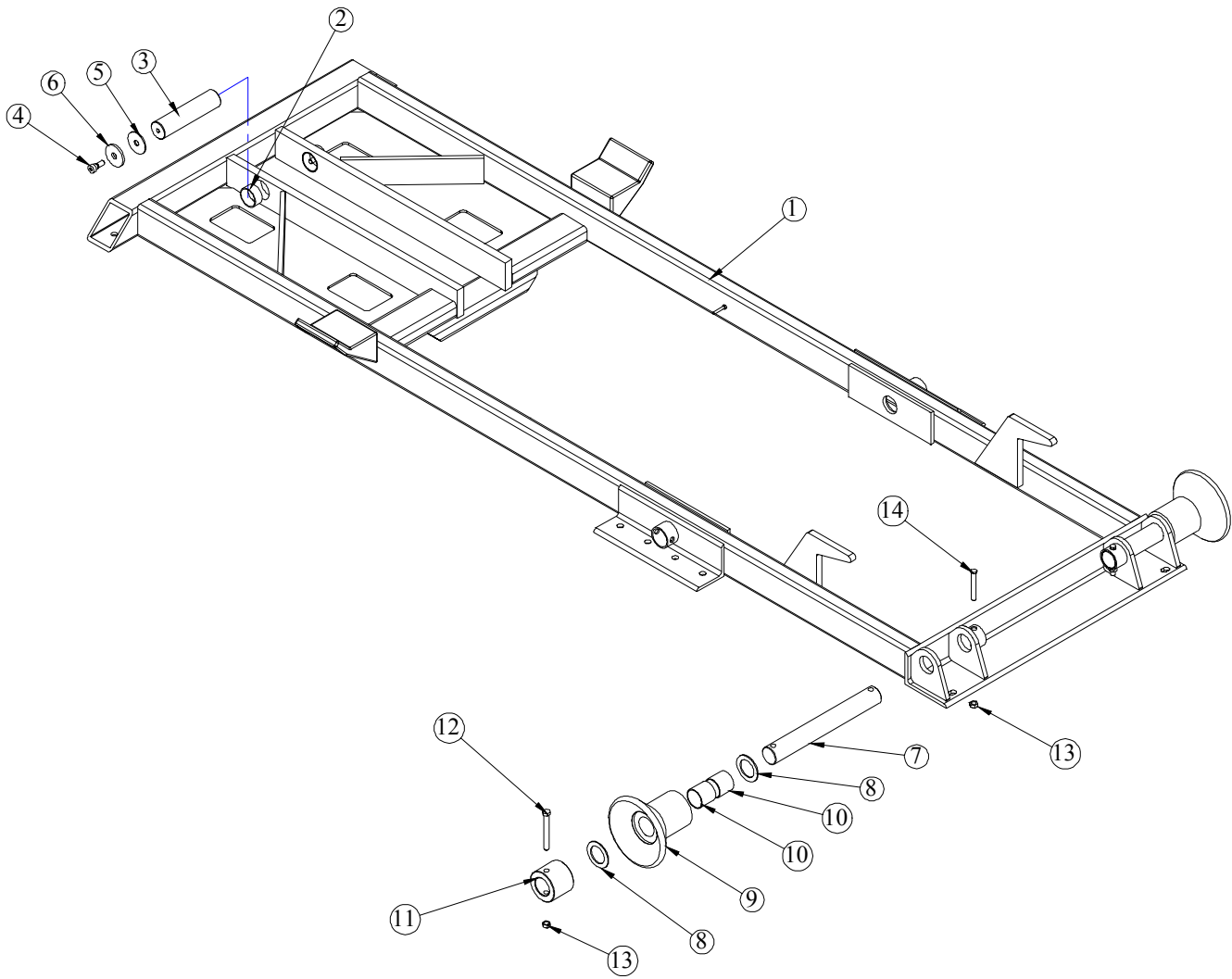

ITEM NO.	PART NO.	DESCRIPTION	QTY.
1	5697	BASE 84-12-9	1
2	8819	BUSHING QSI-3235-16	2
3	16266	PIN 2.00X8.19 D&T	1
4	12673	CAP SCREW 0.50-13 SHOULDER	2
5	15934	THRUST WASHER 0.64x2.50x0.125	2
6	15933	PIN CAP 0.69x2.50x0.25 SS	2
7	4915	PIN DUMP	2
8	1546	THRUST WASHER 2.01DIA UHMW .12THK	4
9	0013	ROLLER	2
10	0066	BUSHING QSI-3235-32	4
11	0015	COLLAR 2.01X3.50X2.88	2
12	0507	CAP SCR 0.50-13X4.50 HHGR5	2
13	C6106	NUT 0.50-13 HHGR5 NYLOC	4
14	0505	CAP SCR 0.50-13X3.50 HHGR5	2

## Secondary Assembly P/N (18320)

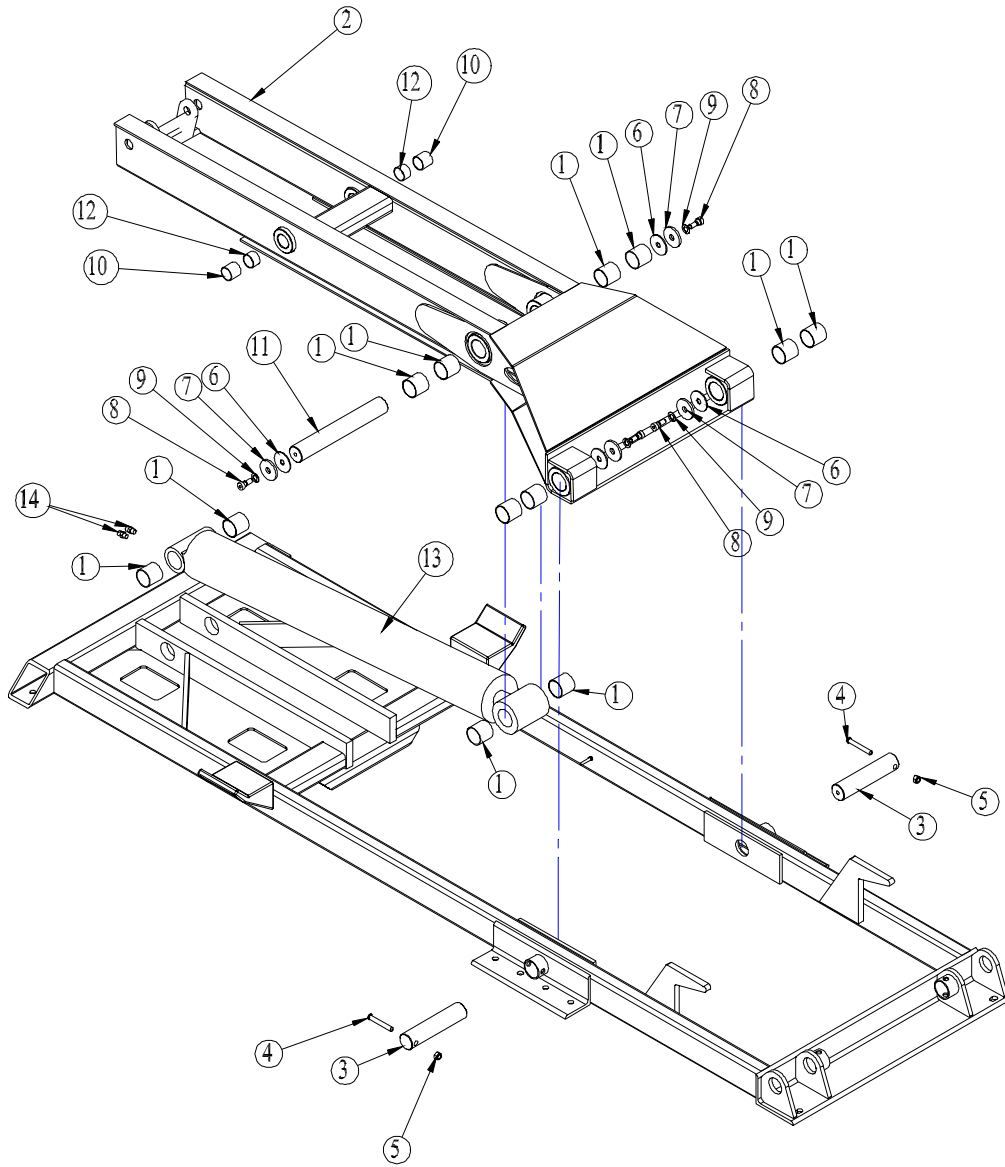

ITEM NO.	PART NO.	DESCRIPTION	QTY.
1	0066	BUSHING QSI-3235-32	12
2	5700	SECONDARY 84-12-9	1
3	4917	PIN 2.00X8.75	2
4	0505	CAP SCR 0.50-13X3.50 HHGR5	2
5	0360	NUT 0.50-13 HH NYLOC	2
6	15934	THRUST WASHER 0.64x2.50x0.125	4
7	15933	PIN CAP 0.69x2.50x0.25 SS	4
8	12673	CAP SCREW 0.50-13 SHOULDER	4
9	12711	THRUST WASHER 0.63 DIA	4
10	0067	BUSHING QSI-2426-24	2
11	17971	PIN 2.00X13.75 D&T	1
12	16067	BUSHING QSI-2426-16	2
13	0057	CYLINDER 5.00X40.38	1
14	0279	FTG ADAPT 6-F5OLO-S	2

## Tilt Assembly P/N (17974)

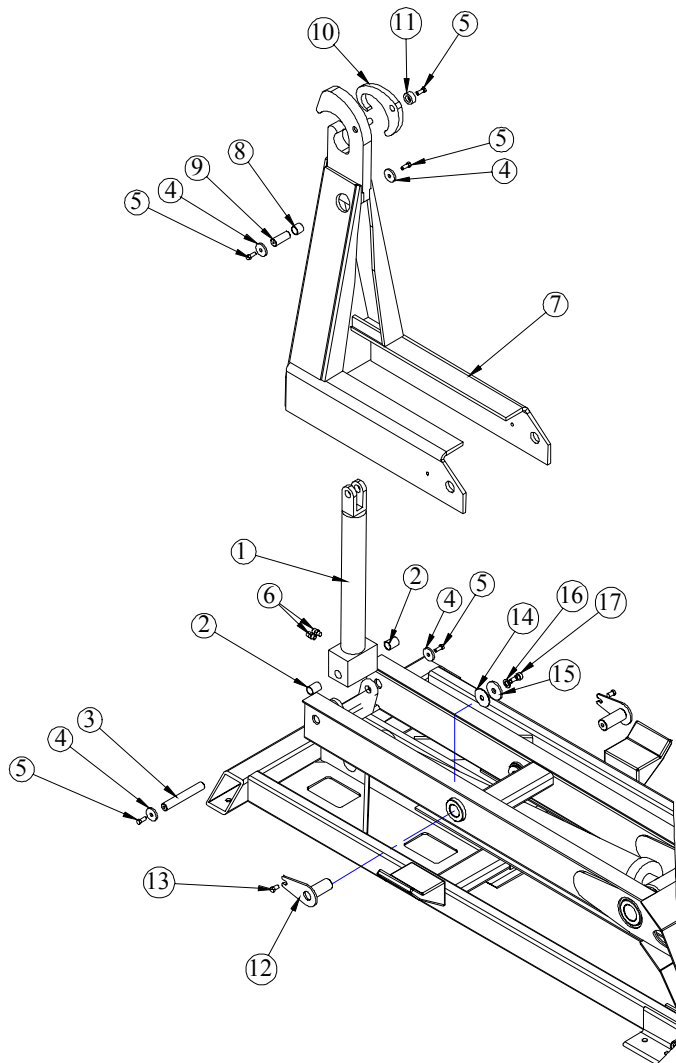

ITEM NO.	PART NO.	DESCRIPTION	QTY.
1	0058	CYLINDER 3.00X14.00	1
2	0068	BUSHING QSI-1618-24	2
3	17973	PIN 1.00X6.75D&T	1
4	9320	PIN CAP 0.44X1.75X0.25 SS	4
5	9714	CAP SCR 0.38-16X1.00 SS	5
6	0279	FTG ADAPT 6-F5OLO-S	2
7	5694	TILT 120-15-13	1
8	0069	BUSHING QSI-1618-16	1
9	14671	PIN 1.00X2.50 D&T	1
10	0295	LATCH 12,000#	1
11	14672	PIN CAP 0.44X1.50X0.63	1
12	4919	PIN TEAR DROP 1.50X3.50	2
13	C0990	CAP SCR 0.50-13X0.75 HHGR5	2
14	15934	THRUST WASHER 0.64x2.50x0.125	2
15	15933	PIN CAP 0.69x2.50x0.25 SS	2
16	12711	THRUST WASHER 0.63 DIA	2
17	12673	CAP SCREW 0.50-13 SHOULDER	2

# INSTALLATION INSTRUCTIONS

## READ ALL INSTRUCTIONS BEFORE PROCEEDING

MOUNT PTO AND PUMP

MOUNT RESERVOIR VALVE COMBO TO TRUCK FRAME

CONNECT SUCTION AND PRESSURE TO TANK, VALVE BANK, AND PUMP

FILL OIL RESERVOIR TO SIGHT GAUGE (MOBIL DTE 13M IS RECOMMENDED)

INSTALL CONTROLLERS AND CABLES IN CAB

SET SHUTTLE ON THE TRUCK SO THAT ITS FRONT PLATE IS AT LEAST 2" BEHIND THE CAB

SQUARE THE SHUTTLE ON THE TRUCK FRAME

DRILL 2-11/16" DIAMETER HOLES THROUGH THE TRUCK FRAME AT THE BACK USING THE LOADER'S HOLES AS A GUIDE

USING 5/8" BOLTS, WASHERS AND NUTS, BOLT THE REAR OF THE LOADER TO THE TRUCK FRAME

SHORTEN THE TRUCK FRAME TO ABOUT 2" FROM THE REAR TO THE LOADER

USING 5/8" BOLTS, WASHERS, AND NUTS FASTEN 2 TIE DOWN CHANNELS TOGETHER WITH THE NARROW FACES TOWARDS EACH OTHER, DO THIS WITH ALL 8 CHANNELS

PLACE THE TIE DOWN CHANNELS IN THE APPROXIMATE POSITIONS SHOWN ON PAGE 8, WITH THE TOP OF THE LOWER CHANNEL FLUSH TO THE TOP OF THE TRUCK FRAME (NOTE: FRONT TIE DOWNS **MUST** BE WITHIN 6 INCHES OF THE FRONT OF THE LOADER)

USING THE MOUNTING CHANNELS AS A GUIDE, DRILL (4) 11/16" HOLES THROUGH THE TRUCK FRAME.

USING 5/8" BOLTS, WASHERS, AND NUTS SECURE ALL TIE DOWNS TO THE TRUCK FRAME

WELD THE UPPER TIE DOWNS TO LOADER BASE

CONNECT HOSES TO VALVE BANK AS INDICATED IN HYDRAULIC ASSEMBLY

SET THE RELIEF VALVE TO 4200 PSI

OPERATE THE LOADER TO ELIMINATE AIR FROM THE SYSTEM

CHECK THE OIL LEVEL AND ADD OIL IF REQUIRED

# Mounting Kit P/N (6262)

WELD WHERE NEEDED

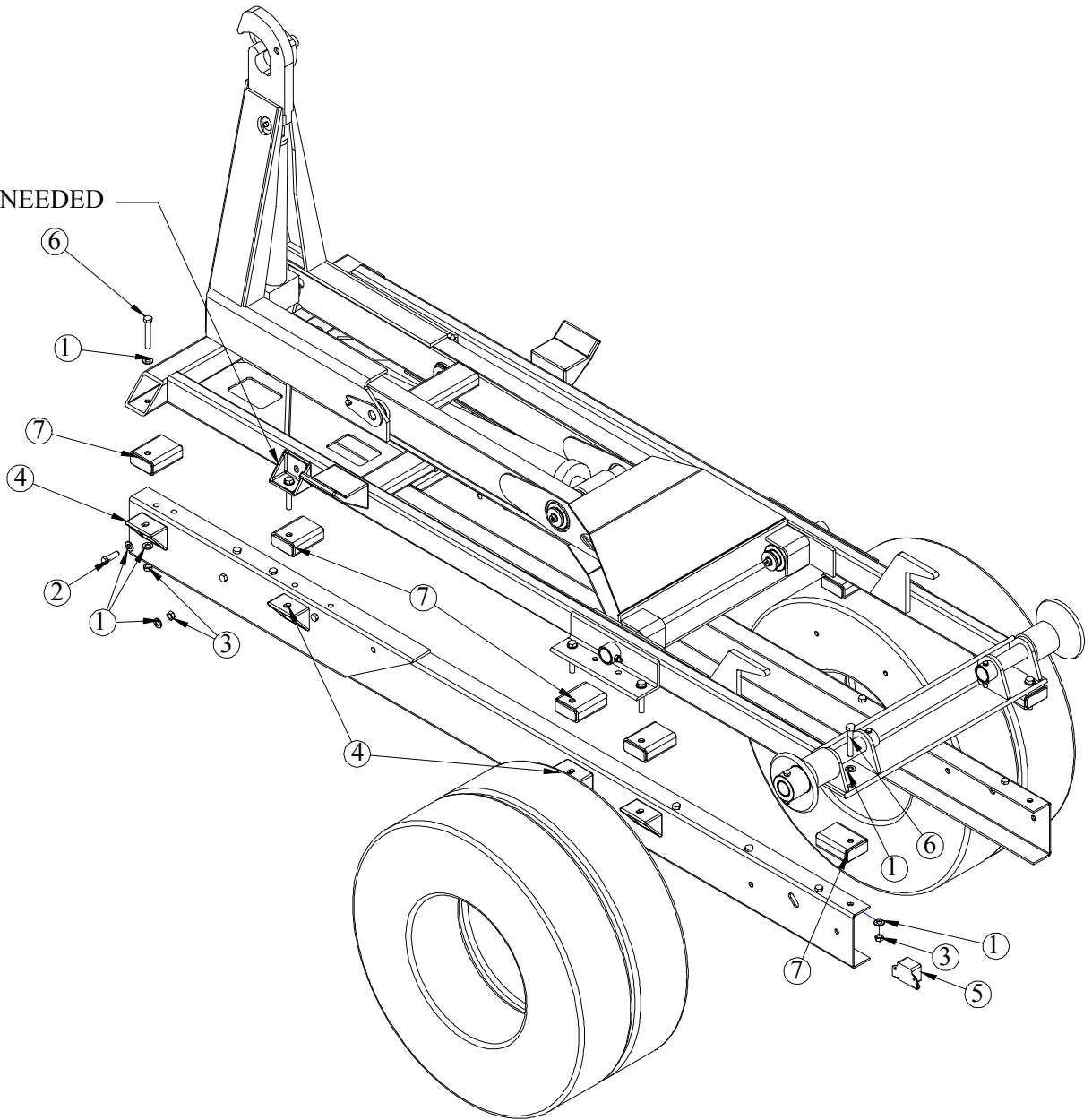

ITEM	PART	DESCRIPTION	QTY.
1	0358	WASHER 0.63 FLAT SAE	36
2	0399	CAP SCR 0.63-11X2.00 HHGR5	8
3	2826	NUT 0.63-11 HH NYLOC	18
4	D0143	TIE DOWN CHANNEL	10
5	D0045	BACKUP ALARM .97 DECIBAL	1
6	2827	CAP SCR 0.63-11X4.00 HHGR5	10
7	16229	TIE DOWN SPACER 2X4	10

## Safety Valve Installation

Incorporated into the standard Stellar Hooklift is a safety valve designed to protect the dump section tabs from being damaged by the tilt section.

It is important to locate this valve properly for safe operation of the Stellar Hooklift.

This cartridge is located in the main valve stack and **MUST** be placed off of the tilt cylinder retract port. The following illustrations show a standard (driver side) installation and an optional (passenger side) installation. Passenger side installations are common when mounting to cab-over chassis. All valve stacks are shipped for standard (driver side) installations. The safety valve must be moved to the tilt cylinder retract port for all non-standard installations. This valve will be switched with a load check plug when being moved to an alternate position. A poppet and spring are located behind the safety valve and load check plugs. Care should be taken not to lose these parts when modifying.

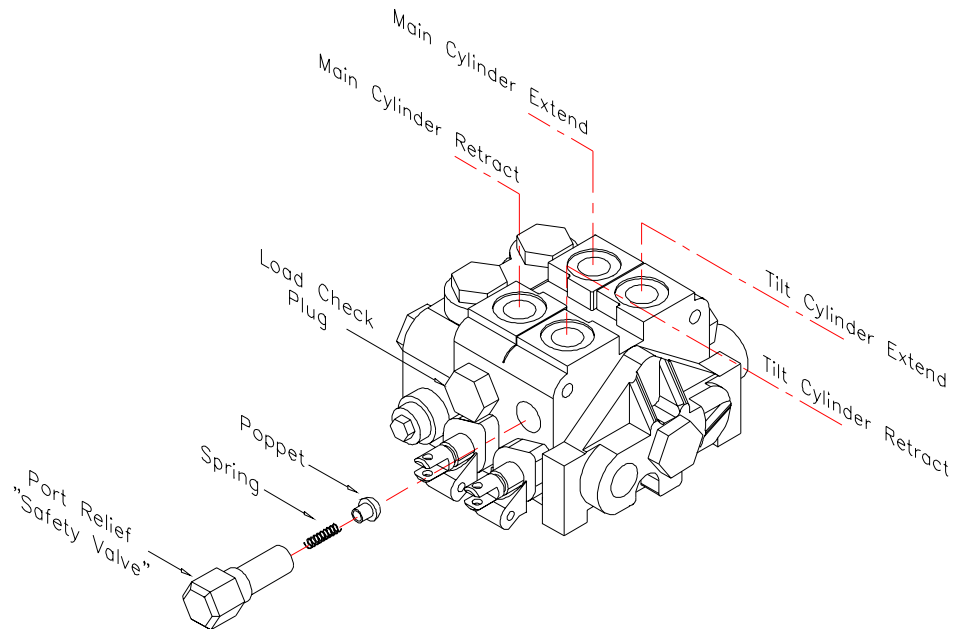

**Valve stack for standard installation**

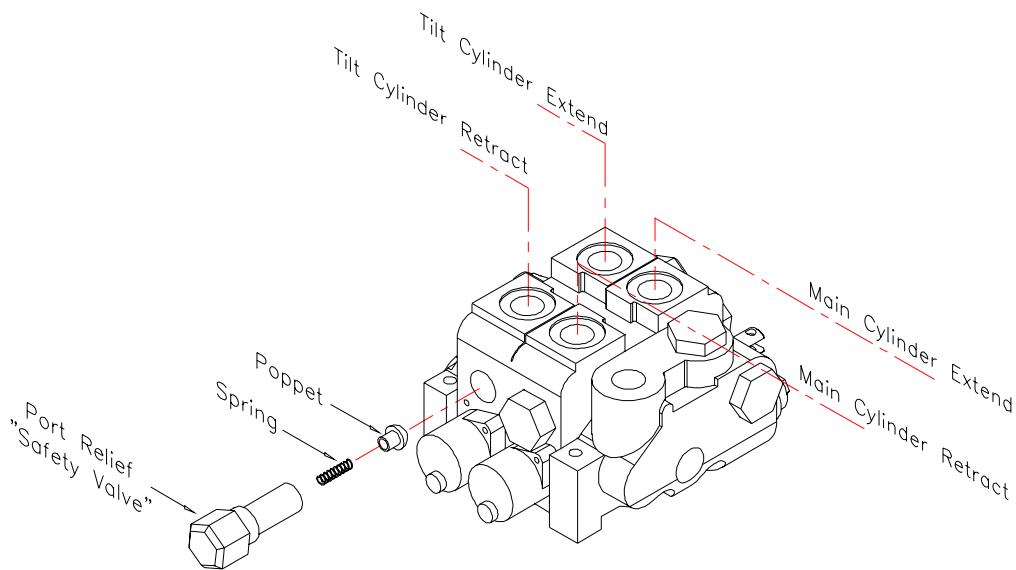

**Valve stack for non-standard installation**

# Hydraulic Assembly P/N (17542)

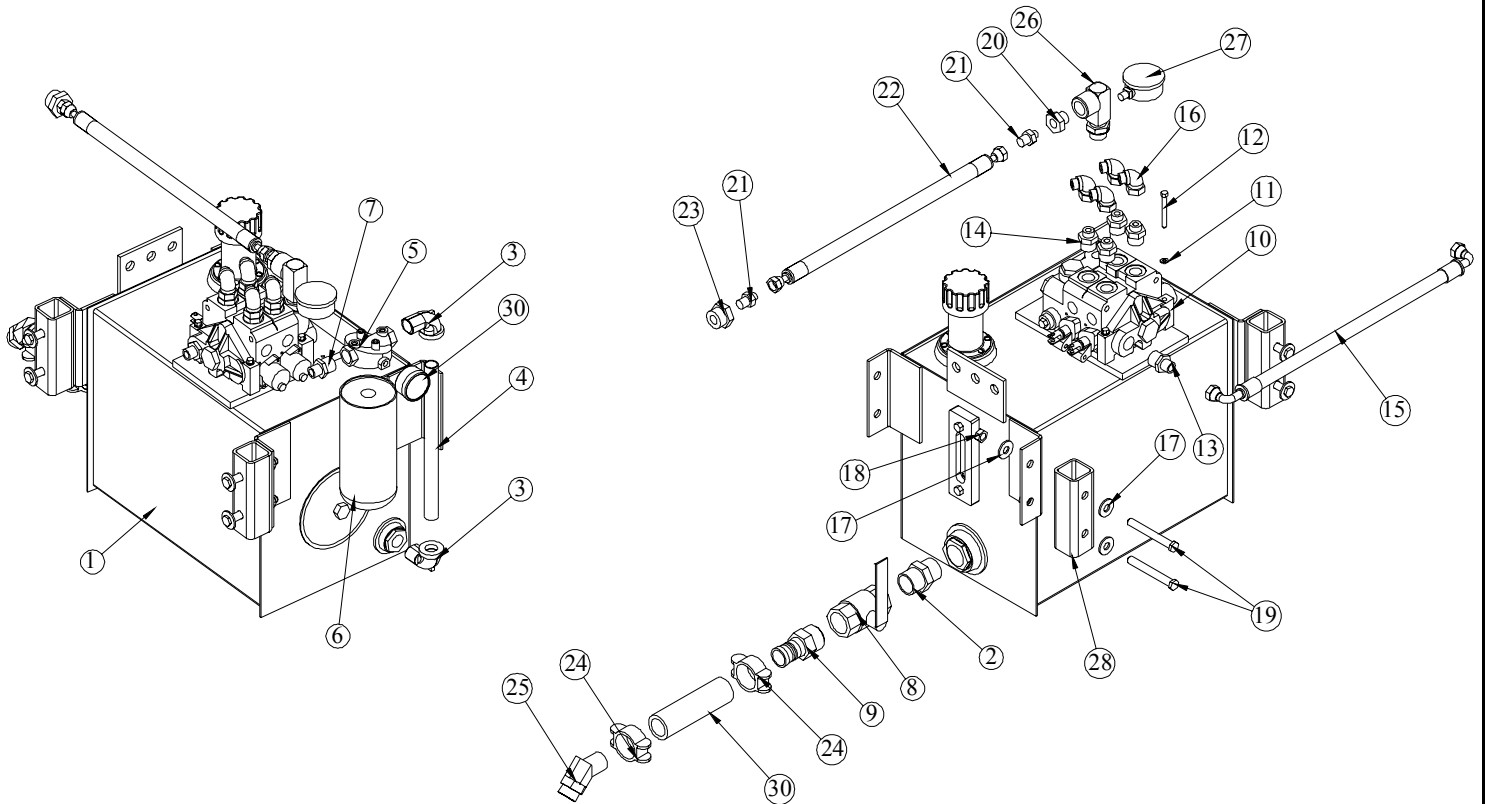

ITEM NO.	PART NO.	DESCRIPTION	QTY.	ITEM NO.	PART NO.	DESCRIPTION	QTY.
1	15623	RSRVR ASM 10GAL	1	16	C2248	FTG ADAPT 6-C6LO-S	4
2	1115	FTG NIPPLE HEX MALE 0101-20-20	1	17	352	WASHER 0.50 USS FLAT ZINC	8
3	c2242	ST EL 0.75 90 DEG BLK	2	18	C6106	NUT 0.50-13 HHGR5 NYLOC	4
4	3320	NIPPLE 0.75X12.00 PIPE	1	19	506	CAP SCR 0.50-13X4.00 HHGR5	4
5	c6226	FILTER HEAD	1	20	C2053	FTG ADAPT 6-8 F5OLO-S	1
6	C6229	FILTER LARGE AE-10L	1	21	C1854	FTG ADAPT 6-8 F5OLO-S	2
7	C6014	FTG ADAPT 8-12 FOLO-S	1	22	14927	HOSE 0.38(381-JC-JC-6-6-6-120)	1
8	C5511	VALVE BALL 1.25	1	23	D0549	FTG ADAPT 16-8 F5OG5-S	1
9	C2282	FTG 1.25 NPT TO 1.25 BARB	1	24	17767	HOSE SUCT 1.25 10FT	1
10	2380	VB 2 SECT GRESEN V20	1	25	C1123	HOSE CLAMP 88 DB-20	2
11	521	WASHER 0.25 LOCK	3	26	C4747	NIPPLE O'RING 45 4603-20-16	1
12	339	CAP SCR 0.25-20X2.50 HHGR5	3	27	14631	FTG MSTR/FSTR 90 12-12 HOOKLIFT	1
13	C1180	FTG ADAPT 8-12 F5OLO-S	1	28	10094	GAUGE OIL LF 2.5" 0-500 BM	1
14	C1855	FTG ADAPT 6-10 F5OLO-S	4	29	9892	SPACER TANK MOUNTING 10 GAL	2
15	14826	HOSE 0.50(381-J9-J9-8-8-8-18-0)	1	30	16145	GAUGE PRES FILTER SERVICE CI20	1

## 10 gal Tank Assembly P/N 15623

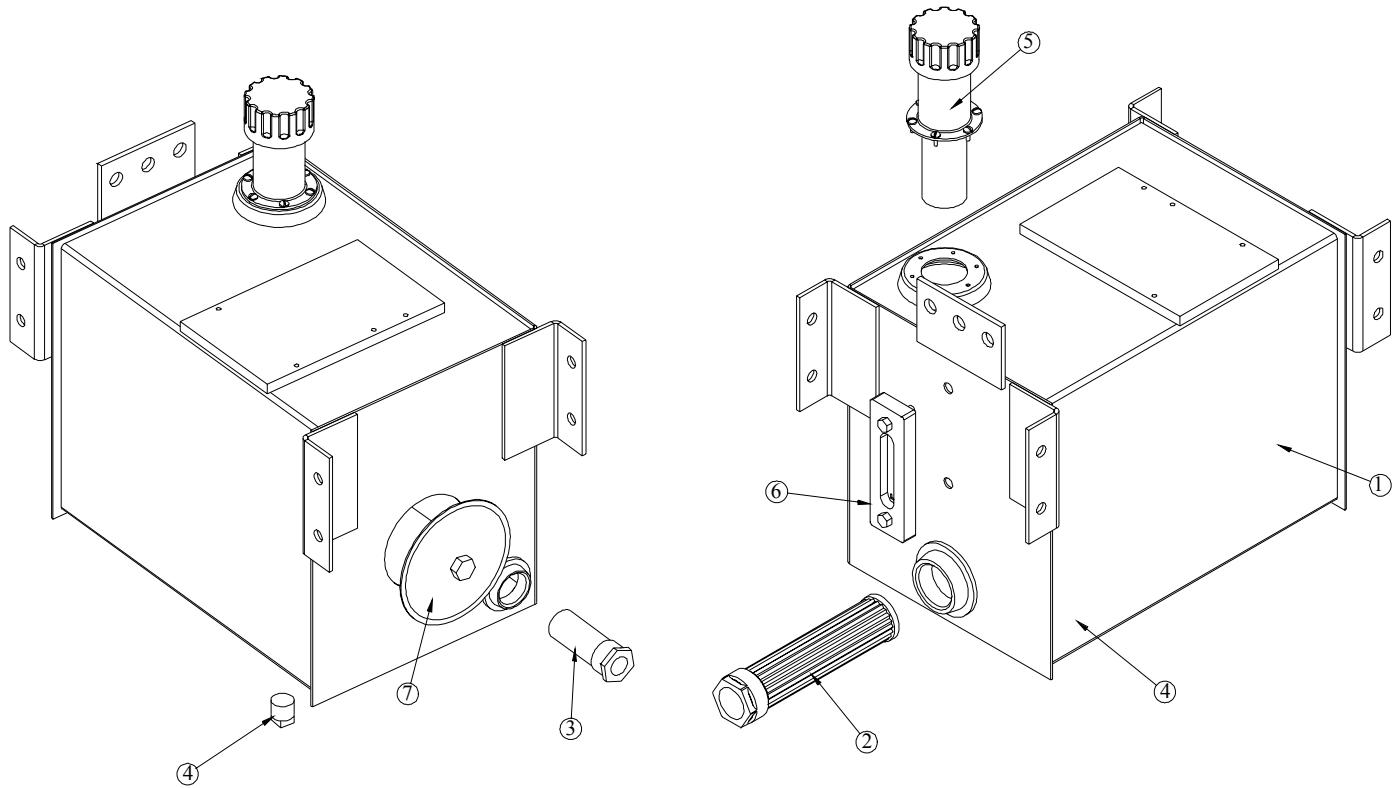

ITEM NO.	PART NO.	DESCRIPTION	QTY.
1	15622	RSRVR 10GAL	1
2	C5552	FILTER STRAINER TF-1220-0	1
3	C6326	DIFFUSER 5-17GAL	1
4	C2126	MAGNETIC PLUG DRAIN 3/4"	1
5	15462	CAP FILL ASM W/3" NECK	1
6	15463	THERMO SIGHT GAUGE	1
7	15464	TANK COVER	1

# HOSE KIT P/N 18056

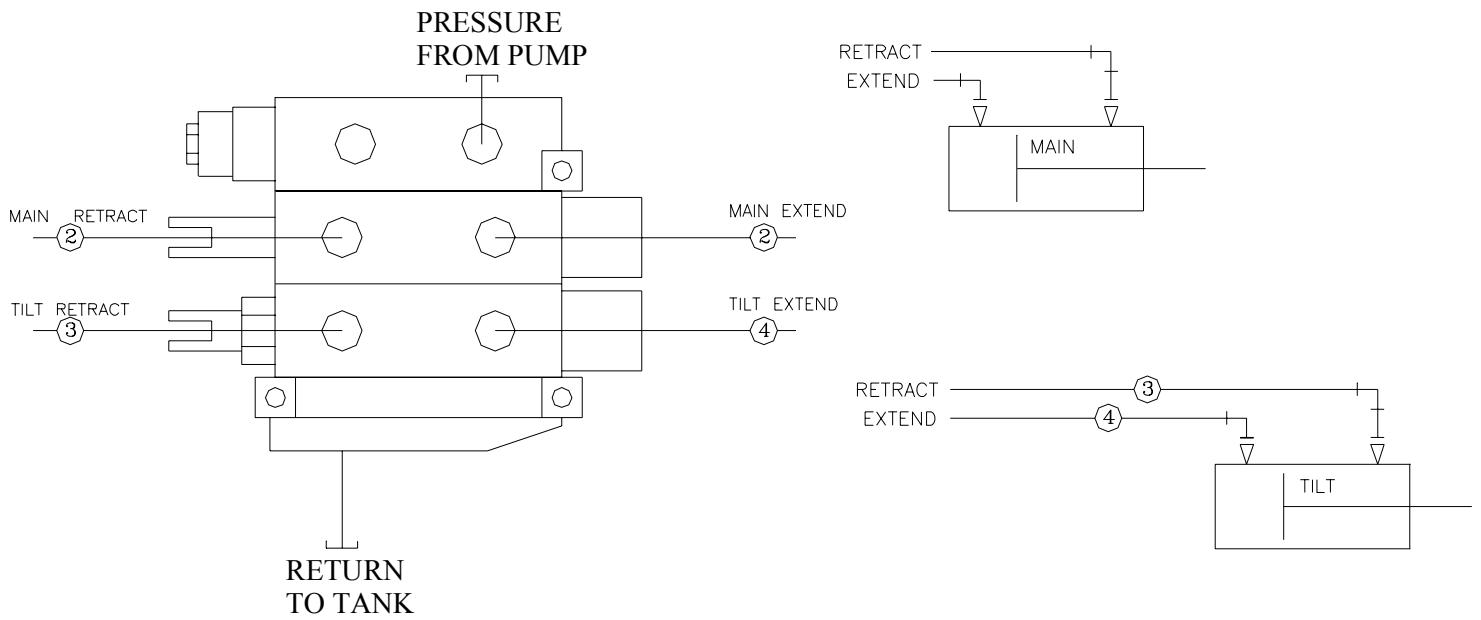

NOTE: IF RESERVOIR IS MOUNTED ON CS  
HOSES 3 AND 4 ARE REVERSED

NOTE: IF RESERVOIR IS MOUNTED ON CS, HOSES 3 AND 4 ARE REVERSED

ITEM NO.	PART NO.	DESCRIPTION	QTY.
1	18056	HOSE KIT 84-12-9	1
2	14827	HOSE 0.38(381-JC-J9-6-6-6-60)	2 REF
3	17975	HOSE 0.25(301-JC-J9-6-6-4-180)	1 REF
4	18057	HOSE 0.25(301-JC-J9-6-6-4-204)	1 REF

# Controller Assembly

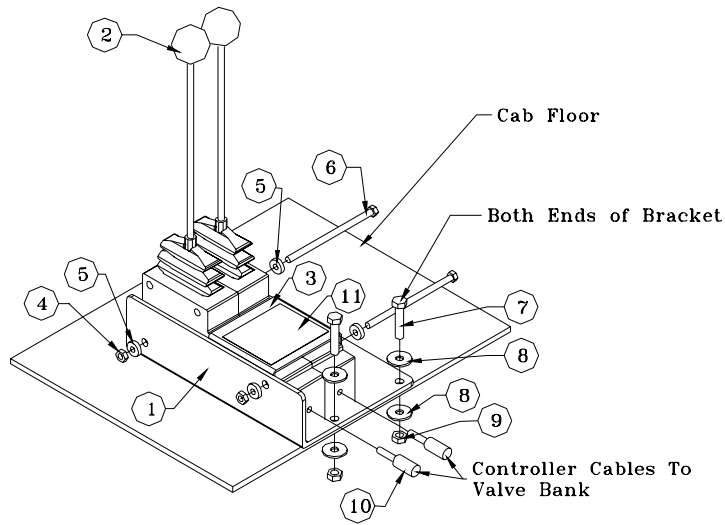

## Controllers

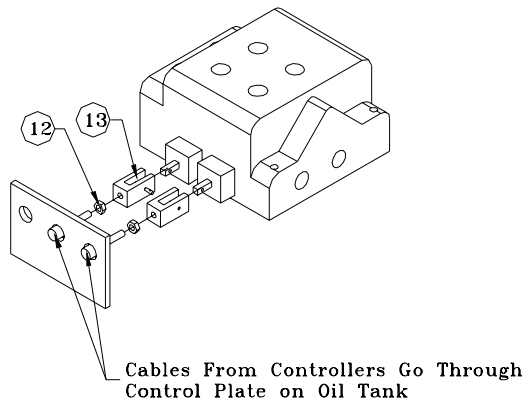

## Valve Bank

ITEM	P/N	DESCRIPTION	QTY	ITEM	P/N	DESCRIPTION	QTY
1	2103	Bracket Controller	1	8	0343	Washer, 0.31 Flat	8
2	0608	Control Lever	2	9	0342	Nut, 0.31-18 Nyloc	4
3	0663	Bracket, Decal	1	10	0607	Controller Cable	2
4	0333	Nut, 0.25-20 Nyloc	2	11	0651	Decal, Operation	1
5	0340	Washer, 0.25 Flat	4	12	1056	Nut, 0.25 Fine Thread	2
6	0528	Cap Screw, 0.25-20x4.50	2	13	0662	Cable Ends, 0.25	2
7	0486	Cap Screw, 0.31-18x1.50	4				

# Subframe

Minimum recommended rail construction.	
84-12-13	5x2x1/4

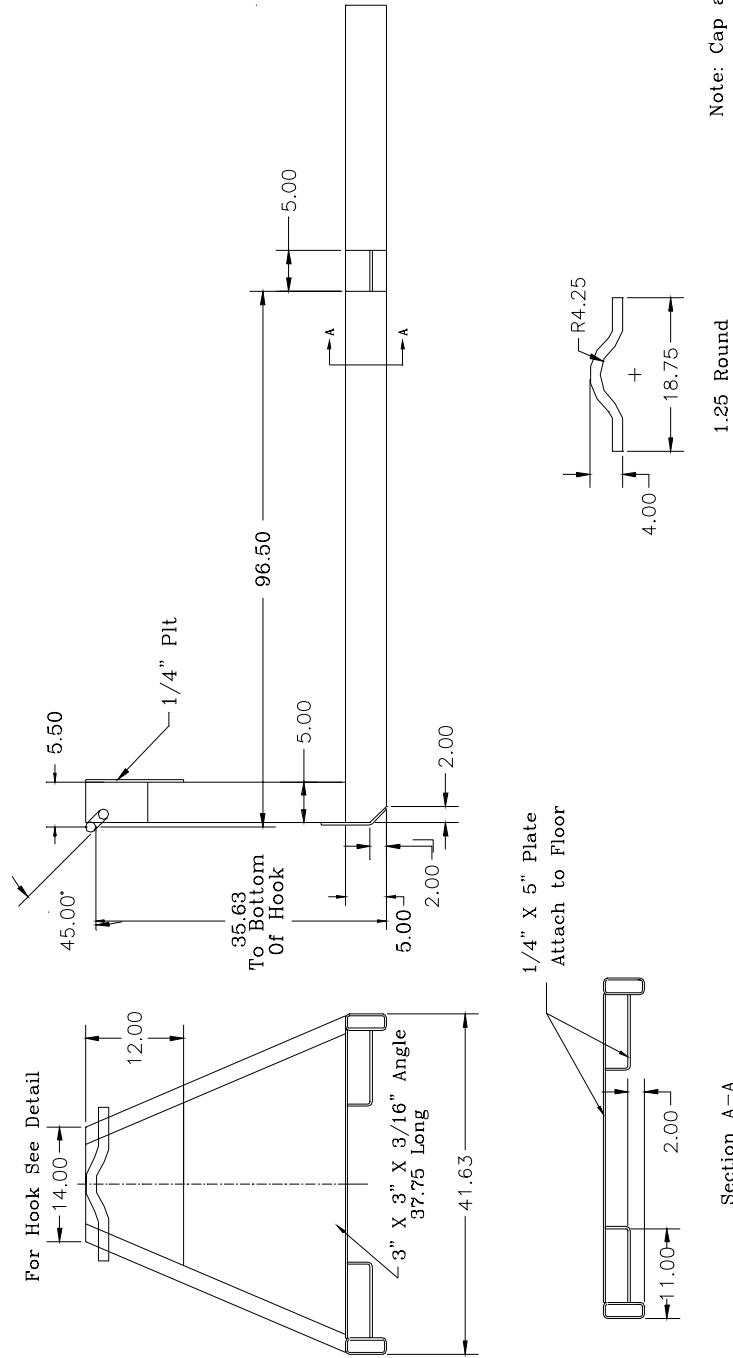

Drawing For Dimensional Purposes Only



### Limited Warranty Statement

Stellar Industries, Inc. (Stellar) warrants products designed and manufactured by Stellar to be free from defects in material and workmanship under proper use and maintenance. Products must be installed and operated in accordance with Stellar's written instructions and capacities. The warranty period shall cover the following:

Twelve (12) month warranty on parts from the date recorded by Stellar as the in-service date, not to extend beyond twenty-four (24) months from date of manufacture,

Twelve (12) month repair labor from the date recorded by Stellar as the in-service date, not to extend beyond twenty-four (24) month from date of manufacture, and

Thirty-six (36) month warranty on all Stellar Crane and Hooklift structural parts from the date recorded by Stellar as the in-service date, not to extend beyond forty-eight (48) months from date of manufacture.

The in-service date will be derived from the completed warranty registration card. In the event a warranty registration card is not received by Stellar, the factory ship date will be used.

Stellar's obligation under this warranty is limited to, and the sole remedy for any such defect shall be, the repair and/or replacement (at Stellar's option) of the unaltered part and/or component in question. Stellar after-sales service personnel must be notified by telephone, fax, or letter of any warranty-applicable damage within fourteen (14) days of its occurrence. If at all possible, Stellar will ship the replacement part within 24-hours of notification by the most economical, yet expedient, means possible. Expedited freight delivery will be at the expense of the owner.

Warranty claims must be submitted and shall be processed in accordance with Stellar's established warranty claim procedure. Stellar after-sales service personnel must be contacted prior to any warranty claim. A return materials authorization (RMA) account number must be issued to the claiming party prior to the return of any warranty parts. Parts returned without prior authorization will not be recognized for warranty consideration. All damaged parts must be returned to Stellar freight prepaid; freight collect returns will be refused. Freight reimbursement of returned parts will be considered as part of the warranty claim.

Warranty service will be performed by any Stellar new equipment distributor, or by any Stellar-recognized service center authorized to service the type of product involved, or by the Stellar factory in the event of a direct sale. At the time of requesting warranty service, the owner must present evidence of date of delivery of the product. The owner shall be obligated to pay for any overtime labor requested of the servicing company by the owner, any field service call charges, and any towing and/or transportation charges associated with moving the equipment to the designated repair/service provider.

All obligations of Stellar and its authorized dealers and service providers shall be voided if someone other than an authorized Stellar dealer provides other than routine maintenance service without prior written approval from Stellar. In the case repair work is performed on a Stellar-manufactured product, original Stellar parts must be used to keep the warranty in force. The warranty may also be voided if the product is modified or altered in any way not approved, in writing, by Stellar.

The owner/operator is responsible for furnishing proof of the date of original purchase of the Stellar product in question. Warranty registration is the ultimate responsibility of the owner and may be accomplished by the completion and return of the Stellar product registration card provided with the product. If the owner is not sure of registration, he is encouraged to contact Stellar at the address below to confirm registration of the product in question. This warranty covers only defective material and workmanship. It does not cover depreciation or damage caused by normal wear and tear, accident, mishap, untrained operators, or improper or unintended use. The owner has the obligation of performing routine care and maintenance duties as stated in Stellar's written instructions, recommendations, and specifications. Any damage resulting from owner/operator failure to perform such duties shall void the coverage of this warranty. The owner will pay the cost of labor and supplies associated with routine maintenance.

The only remedies the owner has in connection with the breach or performance of any warranty on the Stellar product specified are those set above. In no event will Stellar, the Stellar distributor/dealer, or any company affiliated with Stellar be liable for business interruptions, costs of delay, or for any special, indirect, incidental, or consequential costs or damages. Such costs may include, but are not limited to, loss of time, loss of revenue, loss of use, wages, salaries, commissions, lodging, meals, towing, hydraulic fluid, or any other incidental cost.

All products purchased by Stellar from outside vendors shall be covered by the warranty offered by that respective manufacturer only. Stellar does not participate in, or obligate itself to, any such warranty.

Stellar reserves the right to make changes in design or improvement upon its products without imposing upon itself the same upon its products theretofore manufactured.

This warranty will apply to all Stellar Hooklifts, Stellar Service Trucks, & Truck-mounted Cranes shipped from Stellar's factory after July 1, 2005. The warranty is for the use of the original owner only and is not transferable without prior written permission from Stellar.

THIS WARRANTY IS EXPRESSLY IN LIEU OF ANY OTHER WARRANTIES, EXPRESS OR IMPLIED, INCLUDING ANY WARRANTY OF MERCHANTABILITY OR FITNESS FOR A PARTICULAR PURPOSE. REMEDIES UNDER THIS WARRANTY ARE LIMITED TO THE PROVISION OF MATERIAL AND SERVICES, AS SPECIFIED HEREIN. STELLAR INDUSTRIES, INC. IS NOT RESPONSIBLE FOR INCIDENTAL OR CONSEQUENTIAL DAMAGES.

Revision Date: February 2007

Document Number: 37040