



***STELLAR SHUTTLE***  
***MODEL 138-18-32 H***  
***ASSEMBLY***  
***AND***  
***INSTALLATION***  
***MANUAL***



# Table of Contents

Hydraulic Hook Lift Specifications.....	2
Base Assembly .....	3
Dump Assembly .....	4
Secondary Assembly.....	5
Tilt Assembly .....	6
Installation Instructions.....	7
Mounting Kit .....	8
Safety Valve Installation.....	9
Rotary Valve Assembly .....	10
25 Gallon Tank Assembly.....	11
Hydraulic Assembly .....	12
Controller Assembly.....	13
Mounting Kit, 25Gallon.....	14
Miscellaneous Parts .....	14
Subframe .....	15
Warranty.....	16

## Hydraulic Hook Lift Specifications

<b>Lifting Capacity:</b>	32,000 pounds gross weight evenly distributed in, or on, body.
<b>Container Length:</b>	15-foot through 19-foot from front A-frame to rear of skid rails. Longer bodies may be accommodated if full dump angle is not required (may require special body-mounted or extendable truck-mounted bumper to meet the Office of Motor Carrier Safety (OMCS) Rear End Protection regulation 393.86)
<b>Maximum Dump Angle:</b>	45°
<b>Operating Pressure:</b>	4200 PSI maximum
<b>Weight of Loader:</b>	Loader weight not to exceed 4,700 pounds
<b>Height of Loader:</b>	Loader height not to exceed 11" as measured from top of truck frame to top of loader rollers
<b>Hook Height:</b>	61.75-inches from bottom of skid rails to centerline of hook bar. Loader must be able to pick up 10-inches below grade when mounted on a truck with 41" frame height.
<b>Hydraulic Pump:</b>	Direct-coupled high-pressure gear pump.
<b>Hydraulic Control Valve:</b>	Stack-type valve mounted directed onto the oil reservoir.
<b>Controls:</b>	Dual manual levers with sealed cable actuators mounted in the truck cab to allow full feathering of all loader functions.
<b>Tilting Hook Assembly:</b>	Loader must have pivoting type front tilt section (jib) to provide a low degree loading/unloading angle. Hook to include automatic mechanical safety latch, which disengages only when the container/body is in proper position to be picked up or dropped off.
<b>Tilt Cylinder:</b>	Single 4-inch bore with 2-inch diameter rod cylinder. Cylinder must be double acting and include dual integral pilot-operated counterbalance valves to prevent cylinder collapse in case of hose failure.
<b>Tilt Section Operation:</b>	Loader must include a hydraulic lock-out device to prevent operation of the tilt section while loader is in the dumping mode.
<b>Lift/Dump Cylinder:</b>	Single 6-inch bore with 2-1/2-inch diameter rod cylinder. Cylinder must be double acting and include dual integral pilot-operated counterbalance valves to prevent cylinder collapse in case of hose failure.
<b>Dump/Tilt Interlock:</b>	Dumping must be accomplished through a rear pivot. Tilt and lift sections must lock into a rigid full length 25" wide frame with front saddles to provide support for the container while in the dump mode. These sections form this frame without the use of mechanical latches, which rely on gravity, springs, or container/body mounted latches.
<b>Rear Body Hold-Downs:</b>	Dual fixed-position hold-down devices mounted to the dump frame to secure the body to the loader through all ranges of the dump mode. This must be accomplished without the use of steel springs and/or hydraulic/air cylinders.
<b>Rear Dump Hinge Pin:</b>	2-1/2-inch diameter hardened, chrome-plated steel minimum
<b>Pins &amp; Bushings</b>	All pins to be hardened chrome steel. All bushings to be of the permanently lubricated variety. No grease zerks allowed.
<b>Hoses &amp; Hydraulic Fittings:</b>	All hoses and fittings are to be SAE: metrics not allowed. O-ring face seal fittings to be utilized wherever possible.
<b>Origin of Manufacture:</b>	Loader to be designed and manufactured in the United States of America.

## Base Assembly

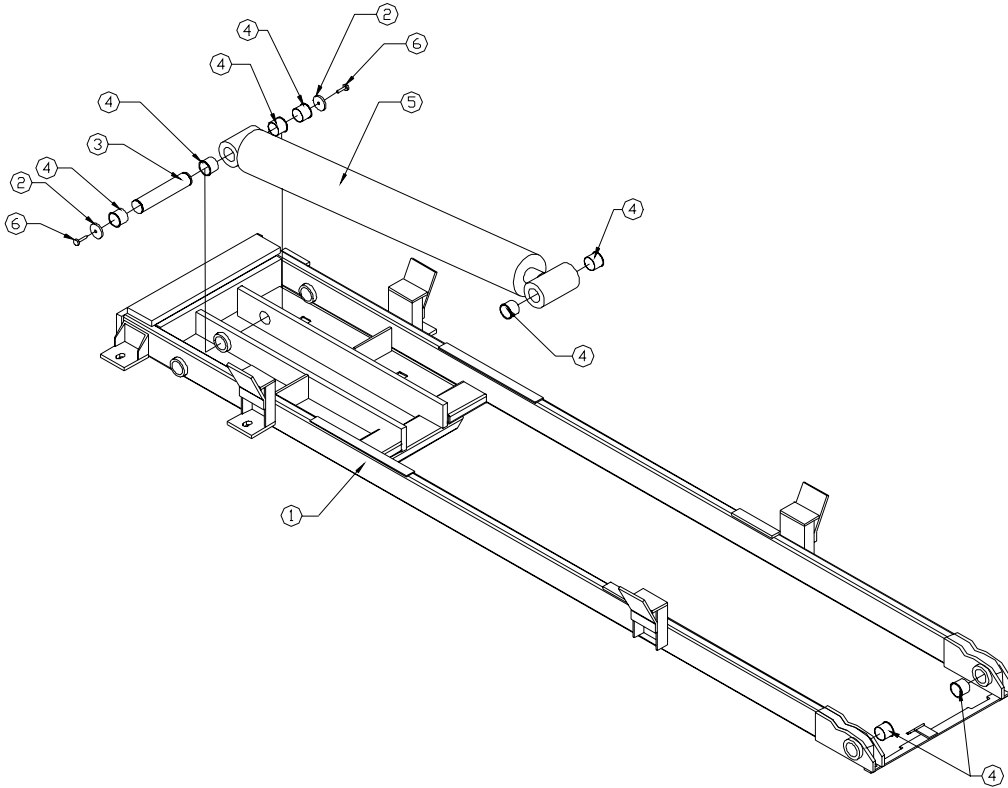

ITEM	P/N	DESCRIPTION	QTY
1	9695	Base Weldment	1
2	8455	Pin Cap .56x3.50x.25	2
3	9730	Pin, 2.50x13.25	1
4	6522	Bushing, GSI-4043-32	8
5	D1727	Cylinder, 6.00x56.50	1
6	8457	Cap Screw .50-13x1.00	2

# Dump Assembly

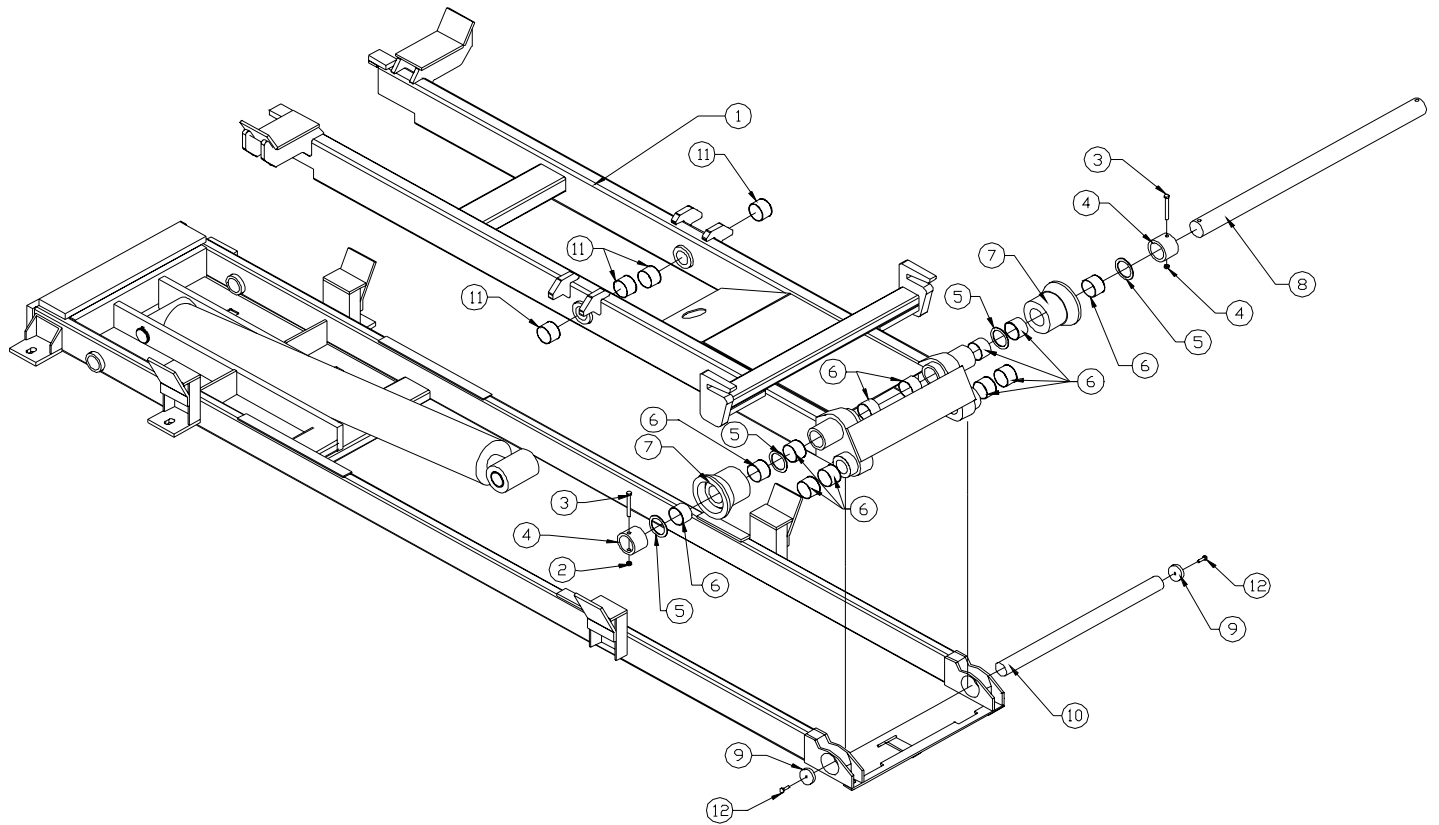

ITEM	P/N	DESCRIPTION	QTY	ITEM	P/N	DESCRIPTION	QTY
1	9697	Dump Weldment	1	7	0813	Roller, 6.00	2
2	C6106	Nut, .50-13 Nyloc	2	8	0859	Pin, 3.00x50.88	1
3	0507	Cap Screw, .50-13x4.50	2	9	8597	Pin Cap .56x4.00x.25	2
4	0866	Collar, Roller	2	10	9763	Pin, 2.50x35.00	1
5	1548	Thrust Washer, 3.01 Dia	4	11	6522	Bushing, GSI-4043-32	4
6	6521	Bushing, GSI-4851-32	12	12	8457	Cap Screw .50-13x1.00	2

## Secondary Assembly

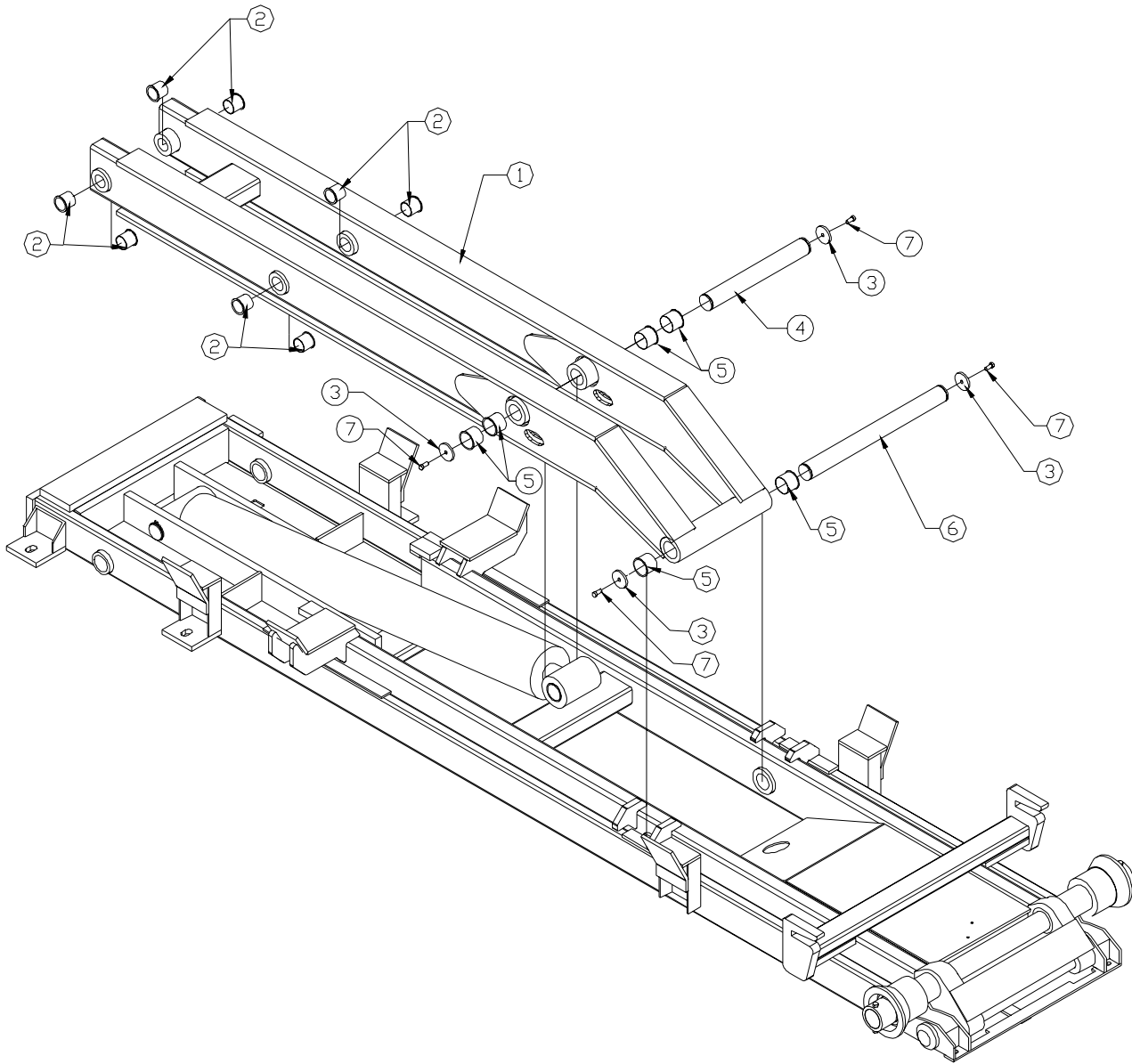

ITEM	P/N	DESCRIPTION	QTY
1	9703	Secondary Weldment	1
2	0066	Bushing, GSI-3235-32	4
3	8597	Pin Cap .56x4.00	4
4	9765	Pin, 2.50x19.50	1
5	6522	Bushing, GSI-4043-32	6
6	9764	Pin, 2.50x27.25	1
7	8457	Cap Screw .50-13x1.00	4

# Tilt Assembly

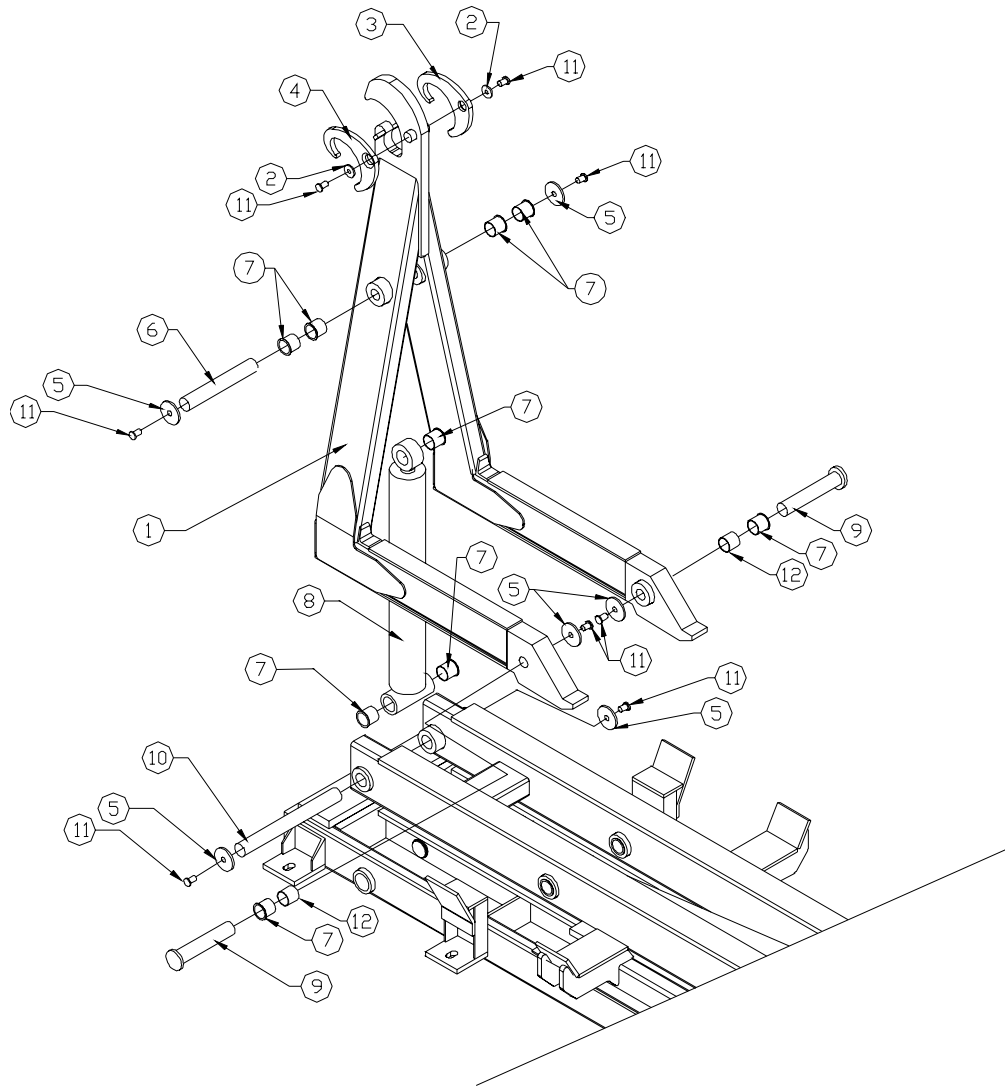

ITEM	P/N	DESCRIPTION	QTY	ITEM	P/N	DESCRIPTION	QTY
1	9721	Tilt Weldment	1	7	0066	Bushing, GSI-3235-32	9
2	8818	Pin Cap .63x2.00x.63	2	8	1748	Cylinder, 4.00x24.50	1
3	2293	Latch, CS 40,000#	1	9	9769	Pin, 2.00x8.38	2
4	0812	Latch, SS 40,000#	1	10	9768	Pin, 2.00x18.25	1
5	5145	Pin Cap .56x3.00x.25	6	11	8457	Cap Screw .50-13x1.00	8
6	9767	Pin 2.00x12.60	1	12	8819	Bushing, Mod 0066	2

# **INSTALLATION INSTRUCTIONS**

## **READ ALL INSTRUCTIONS BEFORE PROCEEDING**

MOUNT PTO AND PUMP

MOUNT RESERVOIR VALVE COMBO TO TRUCK FRAME

CONNECT SUCTION AND PRESSURE TO TANK, VALVE BANK, AND PUMP

FILL OIL RESERVOIR TO 3" OF THE TOP (DEXTRON II IS RECOMMENDED)

INSTALL CONTROLLERS AND CABLES IN CAB

SET SHUTTLE ON THE TRUCK SO THAT ITS FRONT PLATE IS AT LEAST 2" BEHIND THE CAB

SQUARE THE SHUTTLE ON THE TRUCK FRAME

DRILL 2-11/16" DIAMETER HOLES THROUGH THE TRUCK FRAME AT THE BACK USING THE LOADER'S HOLES AS A GUIDE

USING 5/8" BOLTS, WASHERS AND NUTS, BOLT THE REAR OF THE LOADER TO THE TRUCK FRAME

SHORTEN THE TRUCK FRAME TO ABOUT 2" FROM THE REAR TO THE LOADER

USING 1" BOLTS (3 1/2" LONG), WASHERS, AND NUTS ATTACH THE 4 MOUNTING CHANNELS TO THE 4 MOUNTS ON THE LOADER, AS SHOWN IN THE INSTALLATION DRAWING ON PAGE 8

USING THE MOUNTING CHANNELS AS A GUIDE DRILL (4) 1-1/16" HOLES THROUGH THE TRUCK FRAME

LOCATE (4) 1/2X8X16 PLATES, ITEM 5 ON PAGE 8, AND DRILL (2) 1-1/16" HOLES PER PLATE THROUGH BOTH THE PLATE AND THE TRUCK FRAME. INSTALL 1" BOLTS (3" LONG), WASHERS AND NUTS AND SECURE PATES TO THE TRUCK FRAME. THEN WELD THE PLATES DIRECTLY TO THE BASE SECTION OF THE LOADER

USING 1" BOLTS (3" LONG), WASHERS, AND NUTS SECURE ALL TIE DOWNS TO THE TRUCK FRAME AND THE LOADER

CONNECT HOSES TO VALVE BANK AS INDICATED IN HYDRAULIC ASSEMBLY

SET THE RELIEF VALVE TO 4200 PSI

OPERATE THE LOADER TO ELIMINATE AIR FROM THE SYSTEM

CHECK THE OIL LEVEL AND ADD OIL IF REQUIRED

# Mounting Kit

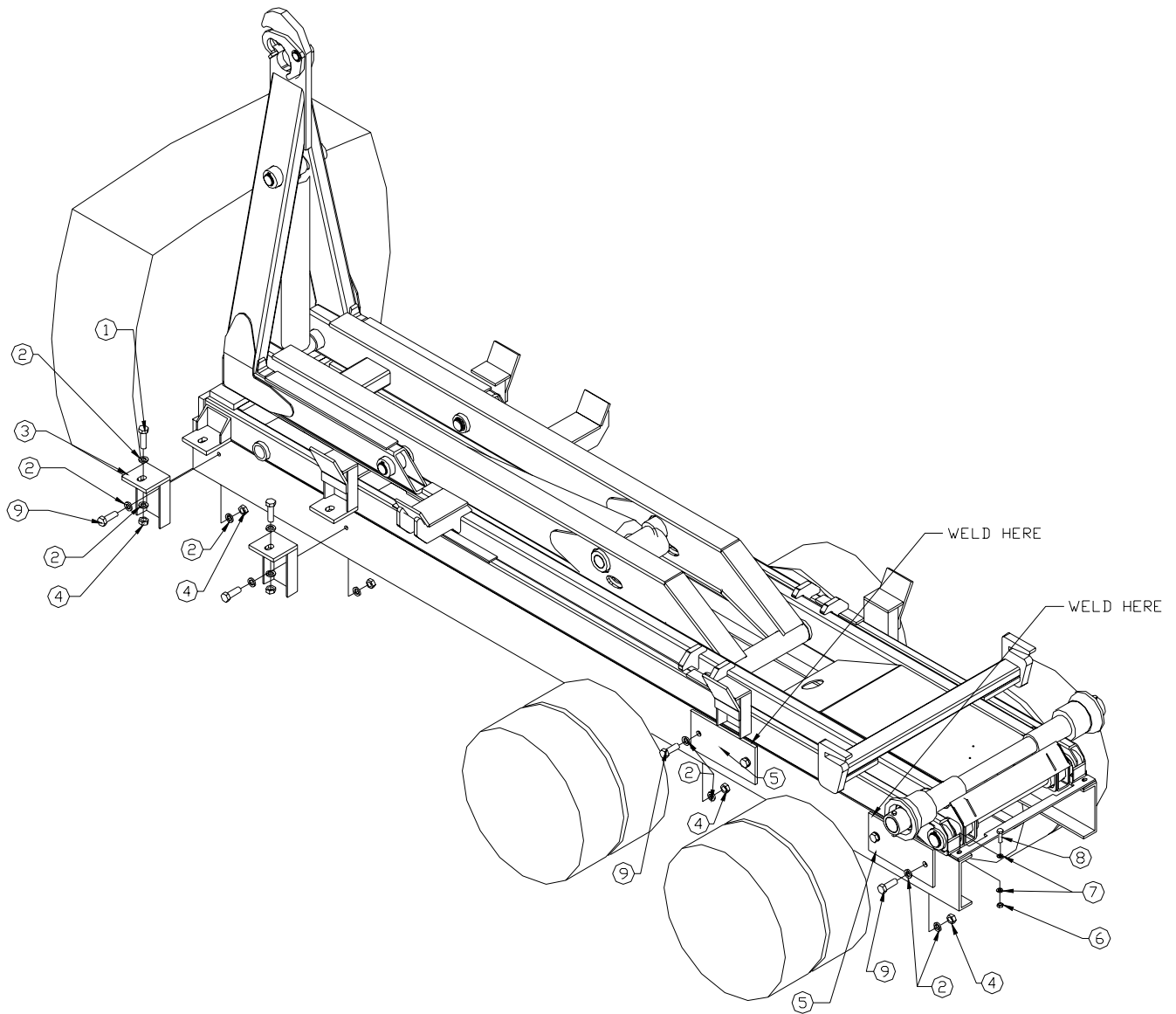

ITEM	P/N	DESCRIPTION	QTY	ITEM	P/N	DESCRIPTION	QTY
1	2830	Cap Screw, 1.00-8x3.50	4	6	2826	Nut, 0.63-11 Nyloc	2
2	1443	Washer, 1.00 Flat	32	7	0358	Washer, .63 SAE	4
3	1440	Tie Down, 40,000#	4	8	0399	Cap Screw, .63-11x2.00	2
4	2829	Nut, 1.00-8 Nyloc	16	9	1442	Cap Screw, 1.00-8x3.00	12
5	3596	Plate, 0.50x8.00x16.00	4				

## Safety Valve Installation

Incorporated into the standard Stellar Hooklift is a safety valve designed to protect the dump section tabs from being damaged by the tilt section.

It is important to locate this valve properly for safe operation of the Stellar Hooklift.

This cartridge is located in the main valve stack and **MUST** be placed off of the tilt cylinder retract port. The following illustrations show a standard (driver side) installation and an optional (passenger side) installation. Passenger side installations are common when mounting to cab-over chassis. All valve stacks are shipped for standard (driver side) installations. The safety valve must be moved to the tilt cylinder retract port for all non-standard installations. This valve will be switched with a load check plug when being moved to an alternate position. A poppet and spring are located behind the safety valve and load check plugs. Care should be taken not to lose these parts when modifying.

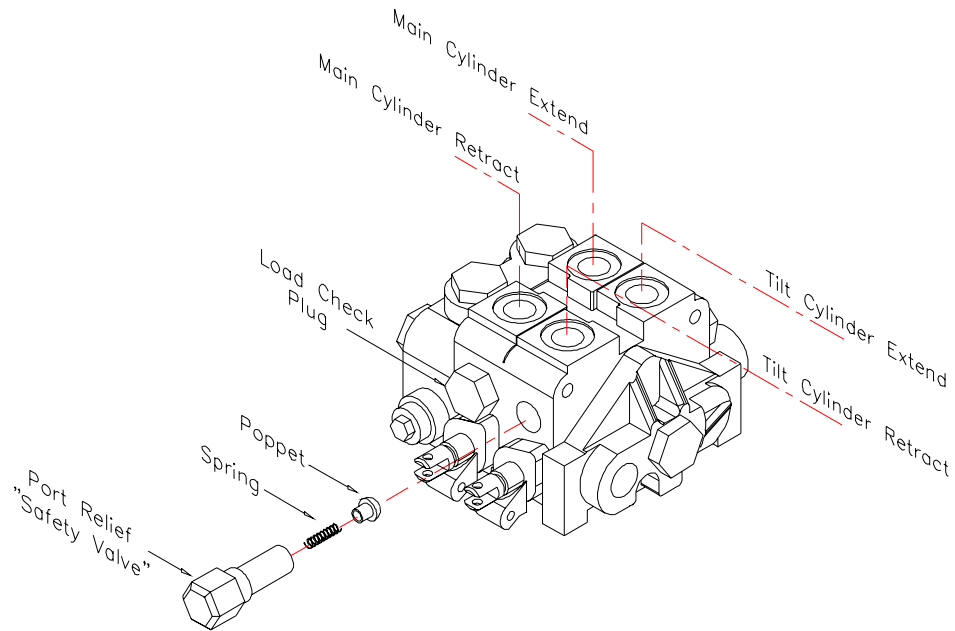

**Valve stack for standard installation**

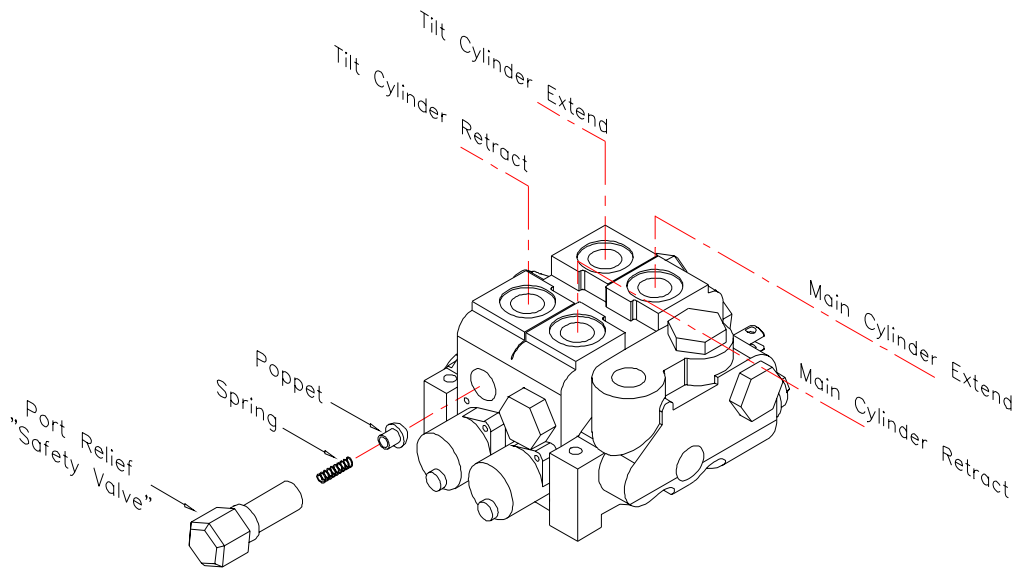

**Valve stack for non-standard installation**

# Rotary Valve Installation

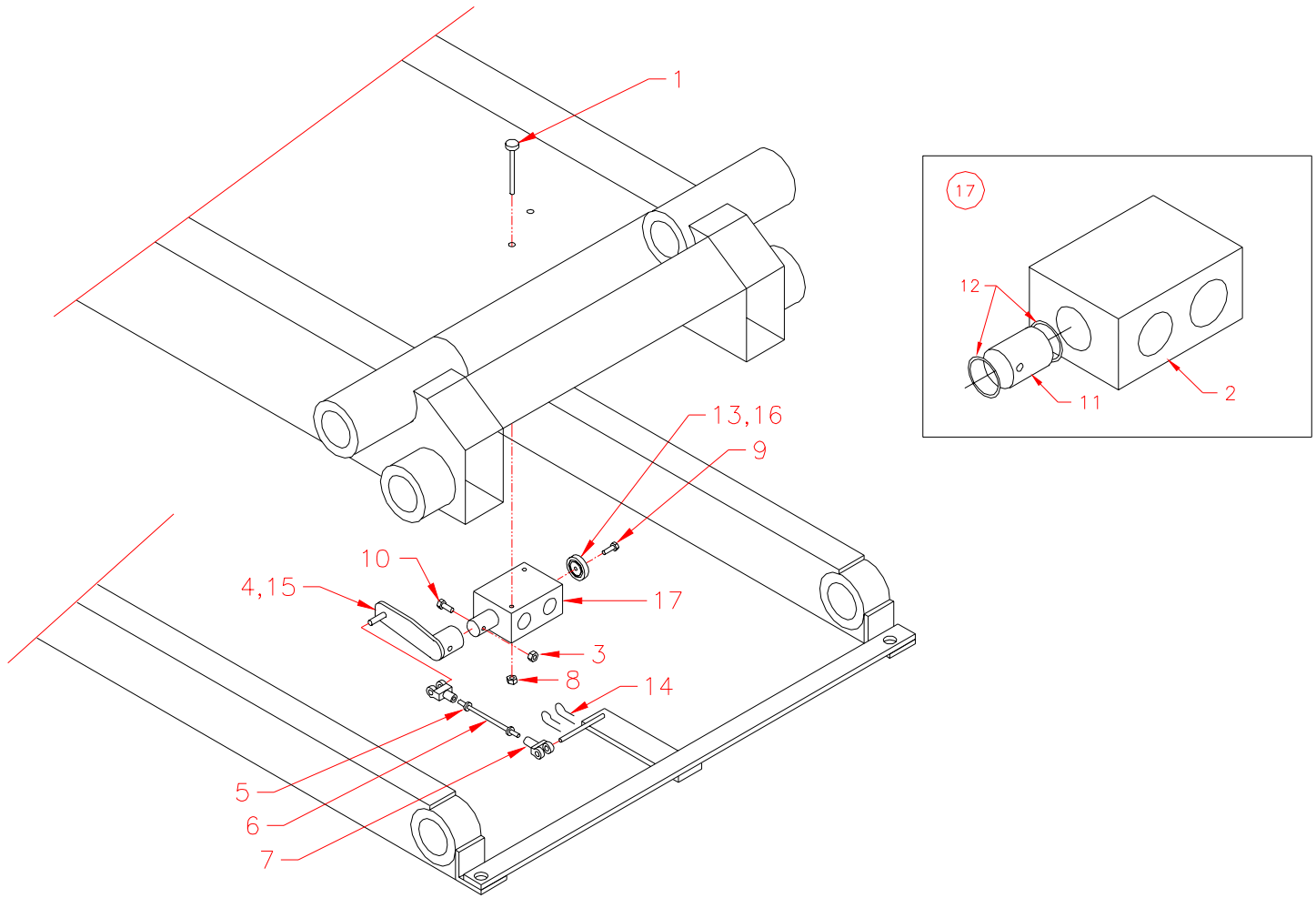

ITEM	P/N	DESCRIPTION	QTY	ITEM	P/N	DESCRIPTION	QTY
1	0482	Cap Screw, 0.25-20x3.00	2	10	0353	Cap Screw, 0.38-16x2.00	1
*2	0933	Body, Rotary Valve	1	*11	D0270	Spool, Rotary Valve	1
3	0347	Nut, 0.38-16 Nyloc	1	*12	0979	Seal, U-Cup	2
4	1521	Rod, Rotary Valve	1	13	3748	Washer, Rotary Valve	1
5	2478	Nut, 0.31-24	2	14	C6113	Cotter, 0.094x1.00	2
6	2476	Rod, 0.31-24 Threaded GR7	12"	15	0977	O'Ring, 1.00x1.25x0.12	1
7	2479	Clevis, 0.31 Pin	2	16	D1638	O'Ring, 1.12x1.38x0.12	1
8	0333	Nut, 0.25-20 Nyloc	2	17	0877	Rotary Valve Assembly	1
9	0480	Cap Screw, 0.25-20x1.00	1				

\* Items are part of #17(0877- Rotary Valve Assembly)

## 25 Gallon Tank Assembly

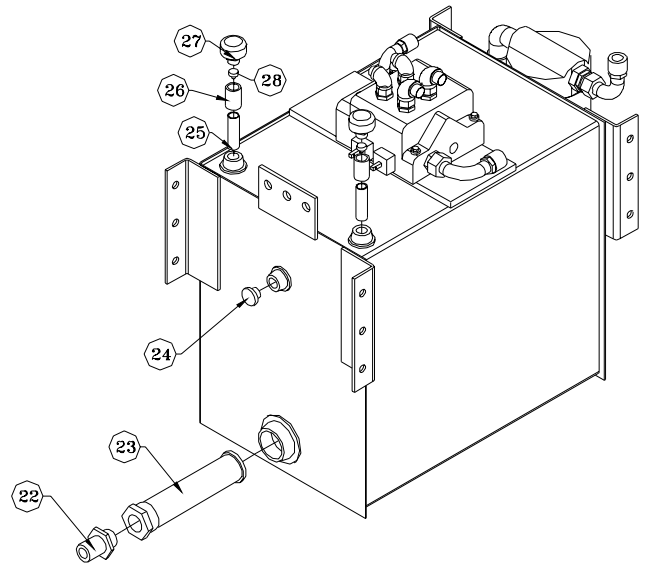
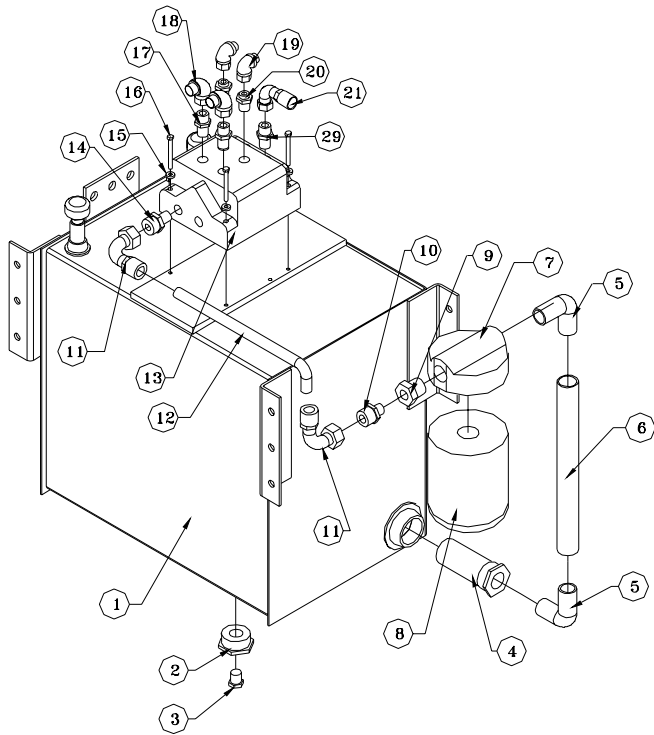

ITEM	P/N	DESCRIPTION	QTY	ITEM	P/N	DESCRIPTION	QTY
1	3501	Tank 25 Gal	1	16	0339	Cap Screw., .25-20x2.50	3
2	C4825	Fitg, Bush Blk 2.50x.75	1	17	C2252	Fitg, Adapter 8-10 F5OLO-S	2
3	C2126	Plug, Magnet .75	1	18	C2376	Fitg, Adapter 8-C6LO-S	2
4	C6328	Diffuser, 25-35 Gal	1	19	C2248	Fitg, Adapter 6-C6LO-S	2
5	C4694	St. Elbow 1.25x90° Blk	2	20	C1855	Fitg, Adapter 6-10 F5OLO-S	2
6	D0024	Nipple, 1.25x14.00 Blk	1	21	1559	Fitg, Hose 1J943-8-8	1
7	C6228	Filter Head SF120-25 1.3	1	22	1563	Nipple, Barb 0588-20-20	1
8	C6225	Filter Large, SE-10	1	23	C5552	Filter, Strainer TF-1220-0	1
9	C2375	Fitg, Reducer 0102-20-12	1	24	C4955	Sight Gauge, .75 Npt Eye	1
10	C4952	Fitg, Adapter 12 FLO-S	1	25	C1053	Nipple, .75x2.50 Blk Pipe	2
11	C4866	Fitg, Seal Lok 90 1J943-12-12	2	26	C5930	Coupler, .75 Blk	2
12	C1585	Hose, Hyd .75 381-12	24"	27	C2151	Cap, Filler Breather	2
13	C4944	Valve Bank, V-20	1	28	C4282	Muffler, Load Genie	2
14	C2142	Fitg, Adapter 12-F5OLO-S	1	29	C1180	Fitg, Adapter 8-12 F5OLO-S	1
15	0521	Washer, .25 Lock	3				

# Hydraulic Assembly

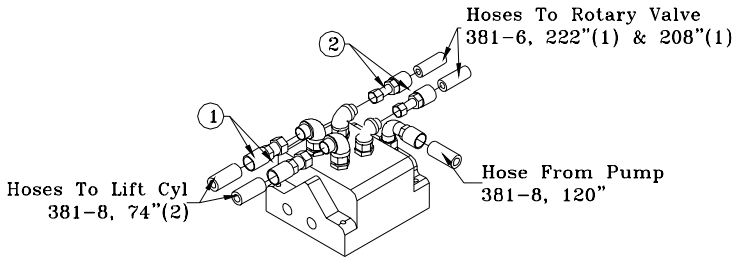

**Valve Bank**

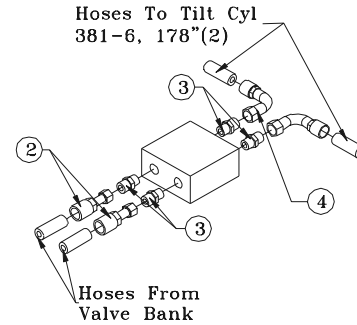

**Rotary Valve**

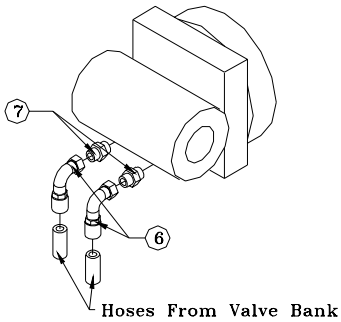

**Lift Cylinder**

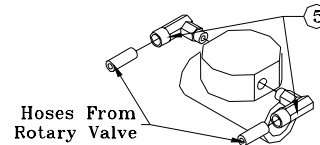

**Tilt Cylinder**

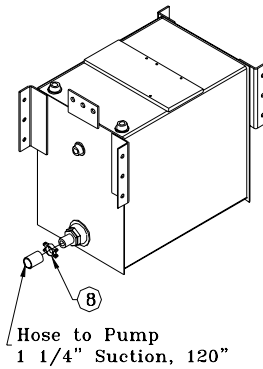

**Suction Line**

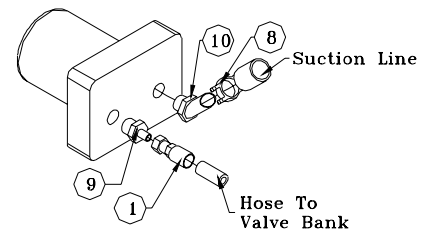

**Standard Pump**

ITEM	P/N	DESCRIPTION	QTY	ITEM	P/N	DESCRIPTION	QTY
1	1558	Hose Ftg, 1JS43 8-8	3	6	1559	Hose Ftg, 1J943 8-8	2
2	C0545	Hose Ftg, 1JS43 6-6	4	7	1554	Adapter, 8-F5OLO-S	2
3	0279	Adapter, 6-F5OLO-S	4	8	C1123	Hose Clamp, 88 DB-20	2
4	C0546	Hose Ftg, 1J943 6-6	2	9	D0549	Adapter, 16-8 F5OG5-S	1
5	1098	Hose Ftg, 10L 43-8-6	2	10	C4747	Ftg, 4603-20-16	1

## Controller Assembly



### Controllers



### Valve Bank

ITEM	P/N	DESCRIPTION	QTY	ITEM	P/N	DESCRIPTION	QTY
1	2103	Bracket Controller	1	8	0343	Washer, 0.31 Flat	8
2	0608	Control Lever	2	9	0342	Nut, 0.31-18 Nyloc	4
3	0663	Bracket, Decal	1	10	0607	Controller Cable	2
4	0333	Nut, 0.25-20 Nyloc	2	11	0651	Decal, Operation	1
5	0340	Washer, 0.25 Flat	4	12	1056	Nut, 0.25 Fine Thread	2
6	0528	Cap Screw, 0.25-20x4.50	2	13	0662	Cable Ends, 0.25	2
7	0486	Cap Screw, 0.31-18x1.50	4				

# Mounting Kit, 25 Gallon Tank

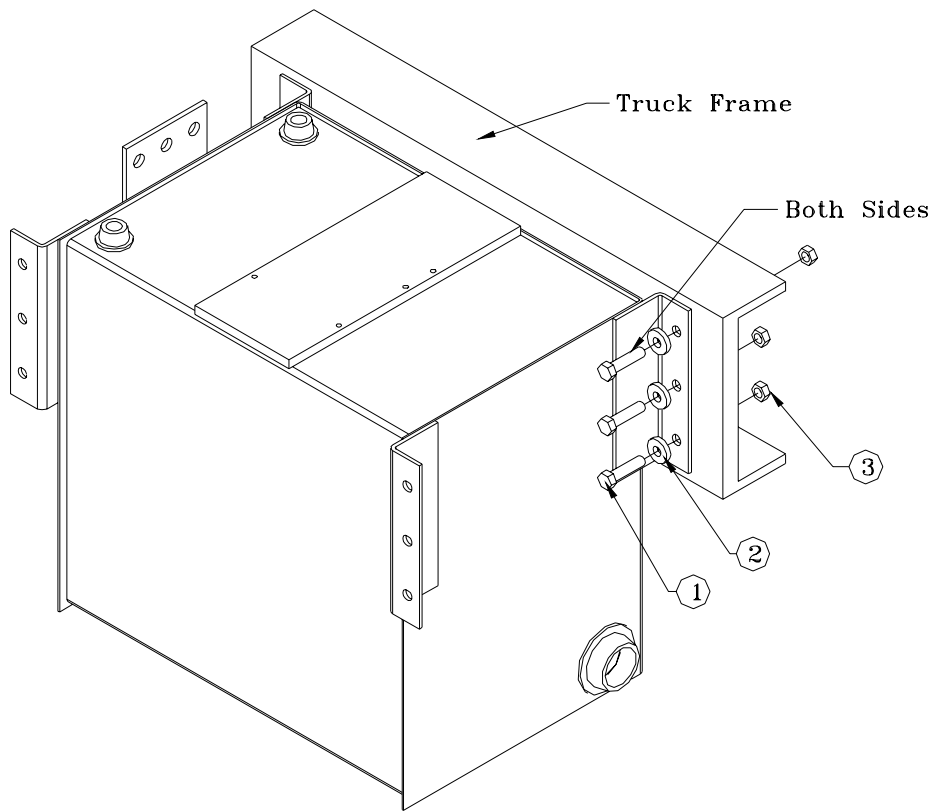

ITEM	P/N	DESCRIPTION	QTY
1	0501	Cap Screw, 0.50-13x2.00	6
2	0352	Washer, 0.50 Flat	6
3	0360	Nut, 0.50-13 Nyloc	6

## Miscellaneous Parts

P/N	DESCRIPTION	QTY
D0045	Alarm, Backup	1

# Subframe

Minimum recommended rail construction per number of rear rollers on loader.	
Single	Double
138-18-32	6x2x1/4 & 1/2x2 Plt
	6x2x1/4

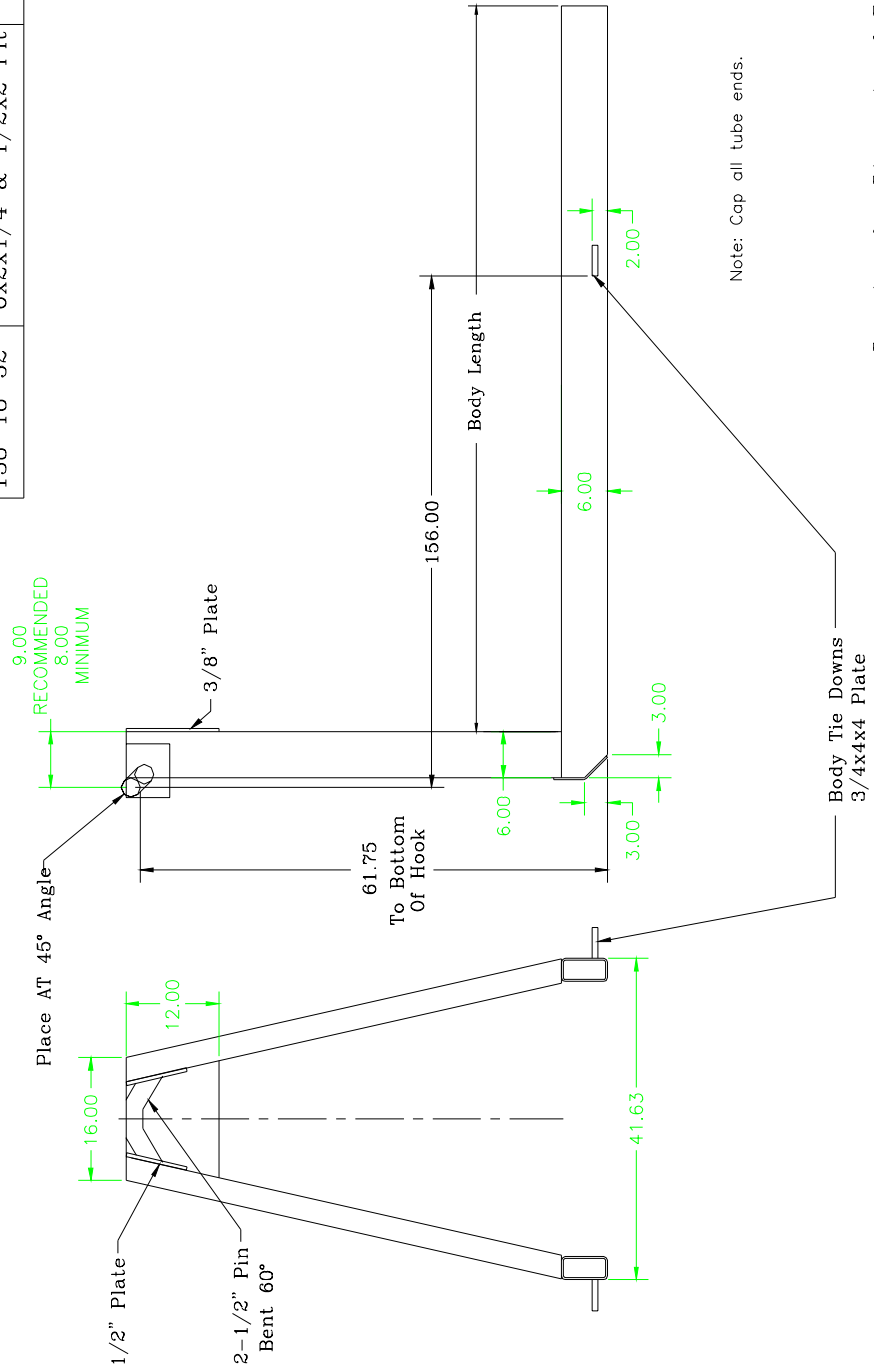

Note: Cap all tube ends.

Drawing for Dimensional Purposes Only

## **Limited Warranty Statement**

for Stellar Shuttle and Exchange Hydraulic Hook Lift Loaders ONLY

Stellar Industries, Inc. (Stellar) warrants products designed and manufactured by Stellar to be free from defects in material and workmanship under proper use and maintenance. Products must be installed and operated in accordance with Stellar's written instructions and stated lifting and dumping capacities. The warranty period shall cover the following:

### **Thirty-Six (36) month warranty on all Stellar designed and fabricated parts, and Ninety (90) days repair labor**

The warranty period shall begin from the date recorded by Stellar as the in-service date. This date will be derived from the completed warranty registration card. In the event a warranty registration card is not received by Stellar, the factory ship date will be used. Stellar's obligation under this warranty is limited to, and the sole remedy for any such defect shall be, the repair and/or replacement (at Stellar's option) of the unaltered part and/or component in question. Stellar after-sales service personnel must be notified by telephone, fax, or letter of any warranty-applicable damage within fourteen (14) days of its occurrence. If at all possible, Stellar will ship the replacement part within 24-hours of notification by the most economical, yet expedient, means possible. Expedited freight delivery will be at the expense of the owner.

Warranty claims must be submitted and shall be processed in accordance with Stellar's established warranty claim procedure. Stellar Service personnel must be contacted prior to any warranty claim. A return materials authorization (RMA) account number must be issued to the claiming party prior to the return of any warranty parts. Parts returned without prior authorization will not be recognized for warranty consideration. All damaged parts must be returned to Stellar freight prepaid; freight collect returns will be refused.

Warranty service will be performed by any Stellar Shuttle/Exchange new equipment distributor, or by any Stellar-recognized service center authorized to service Stellar hook lift products, or by the Stellar factory. At the time of requesting warranty service, the owner must present evidence of date of delivery of the product. The owner shall be obligated to pay for any overtime labor requested of the servicing company by the owner, any field service call charges, and any towing and/or transportation charges associated with moving the equipment to the designated repair/service provider.

All obligations of Stellar and its authorized dealers and service providers shall be voided if someone other than an authorized Stellar dealer provides other than routine maintenance service without prior written approval from Stellar. In the case repair work is performed on a Stellar hook lift, original Stellar parts must be used to keep the warranty in force. The warranty may also be voided if the product is modified or altered in any way not approved, in writing, by Stellar engineering.

The owner/operator is responsible for furnishing proof of the date of original purchase of the Stellar Shuttle or Exchange hook lift loader. Warranty registration is the ultimate responsibility of the owner and may be accomplished by the completion and return of the Stellar product registration card provided with the product. If the owner is unsure of registration, he is encouraged to contact Stellar at the address below to confirm registration of the product in question. This warranty covers only defective material and workmanship. It does not cover depreciation or damage caused by normal wear and tear, accident, mishap, untrained operators, or improper or unintended use. The owner has the obligation of performing routine care and maintenance duties as stated in Stellar's written instructions, recommendations, and specifications. Any damage resulting from owner/operator failure to perform such duties shall void the coverage of this warranty. The cost of labor and supplies associated with routine maintenance will be paid by the owner.

The only remedies the owner has in connection with the breach or performance of any warranty on the Stellar product specified are those set above. In no event will Stellar, the Stellar distributor/dealer, or any company affiliated with Stellar be liable for business interruptions, costs of delay, or for any special, indirect, incidental, or consequential costs or damages. Such costs may include, but are not limited to, loss of time, loss of revenue, loss of use, wages, salaries, commissions, lodging, meals, towing, hydraulic fluid, or any other incidental cost.

All products purchased by Stellar from outside vendors shall be covered by the warranty offered by that respective manufacturer only. Stellar does not participate in, or obligate itself to, any such warranty.

Hydraulic cylinders used in Stellar products are subject to the same warranty provisions stated above. Should a cylinder defect develop within the above stated warranty period, notify Stellar immediately. Stellar will ship, freight prepaid, by the most cost effective, yet expedient, means a new or re-manufactured cylinder of the same size and type. An authorization for return of the original part will be issued at the time the order is placed. The defective cylinder is to be returned freight prepaid by the owner. Cylinders returned freight collect will be refused. Should the defective cylinder not be returned within 30 days of shipping the replacement cylinder, the owner is responsible to pay Stellar the full purchase price of the replacement part.

Stellar reserves the right to make changes in design or improvement upon its products without imposing upon itself the same upon its products theretofore manufactured.

This warranty will apply to all Stellar Shuttle and Exchange hydraulic hook lift loaders shipped from Stellar's factory after January 1, 1997. The warranty is for the use of the original owner only and is not transferable without prior written permission from Stellar.

**THIS WARRANTY IS EXPRESSLY IN LIEU OF ANY OTHER WARRANTIES, EXPRESS OR IMPLIED, INCLUDING ANY WARRANTY OF MERCHANTABILITY OR FITNESS FOR A PARTICULAR PURPOSE. REMEDIES UNDER THIS WARRANTY ARE LIMITED TO THE PROVISION OF MATERIAL AND SERVICES, AS SPECIFIED HEREIN. STELLAR INDUSTRIES, INC. IS NOT RESPONSIBLE FOR INCIDENTAL OR CONSEQUENTIAL DAMAGES.**

**Stellar Industries, Inc. • 280 West Third Street • Garner, Iowa 50438  
U.S.A. Telephone: 800/392-3015; 515/923-3741 • Fax: 515/923-2812; 515/923-2811**

revised1/1/97