



STELLAR SHUTTLE
MODEL 120-16-20 K
(P/N 23831)
ASSEMBLY
AND
INSTALLATION
MANUAL

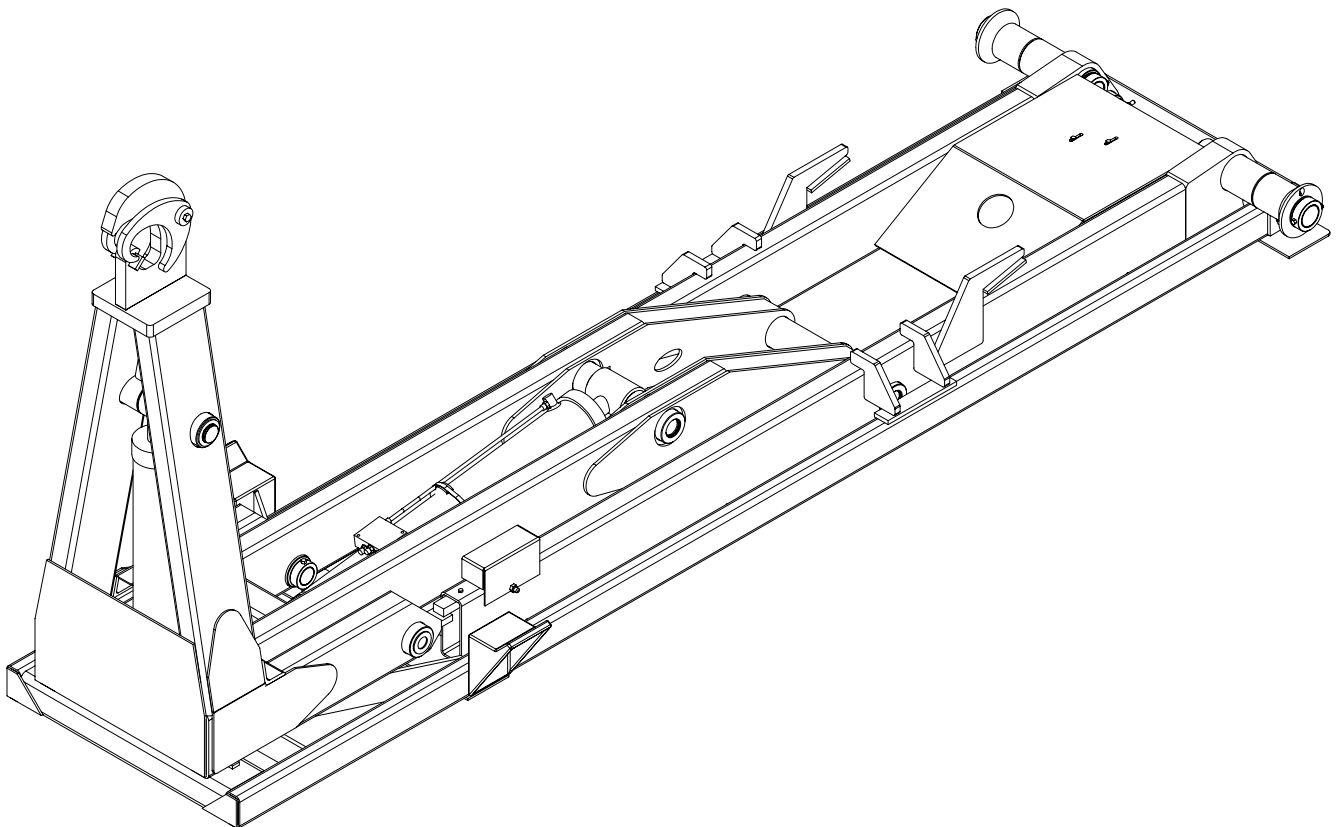

Table of Contents

Hydraulic Hook Lift Specifications	2
Base Assembly	3
Dump Assembly	4
Secondary Assembly	5
Tilt Assembly	6
Main Cylinder Assembly.....	7
Tilt Cylinder Assembly	8
Installation Instructions	9
Mounting Kit	10
Rotary Valve Installation.....	11
10 Gallon Hydraulic Assembly	12
10 Gallon Tank Assembly.....	13
Hose Kit.....	14
Controller Assembly.....	15
Controller Assembly continued.....	16
Decal Placement	17
Subframe	18
Warranty.....	19

Hydraulic Hook Lift Specifications

Lifting Capacity:	20,000 pounds gross weight evenly distributed in, or on, body.
Container Length:	12.50-foot through 15-foot from front A-frame to rear of skid rails. Longer bodies up to 17 feet may be accommodated if full dump angle is not required (may require special body-mounted or extendable truck-mounted bumper and additional latches to meet the Federal Motor Carrier Safety Administration (FMCSA) Rear End Protection regulation 393.86 and Securing Hook lift Containers regulation 393.134).
Maximum Dump Angle:	48°
Operating Pressure:	4200 PSI maximum.
Weight of Loader:	Loader weight not to exceed 2,625 pounds.
Height of Loader:	Loader height not to exceed 8.38” as measured from top of truck frame to top of loader rollers.
Hook Height:	54-inches from bottom of skid rails to centerline of hook bar. Loader must be able to pick up 10-inches below grade when mounted on a 41” truck frame height.
Hydraulic Pump:	Direct-coupled high-pressure gear pump.
Hydraulic Control Valve:	Hydraulic valve mounted directly onto the oil reservoir.
Controls:	Dual manual levers with sealed cable actuators mounted in the truck cab to allow full feathering of all loader functions.
Tilting Hook Assembly:	Loader must have pivoting type front tilt section (jib) to provide a low degree loading/unloading angle. Hook to include automatic mechanical safety latch, which disengages only when the container/body is in proper position to be picked up or dropped off.
Tilt Cylinder:	Single 4-inch bore with 2-inch diameter rod cylinder. Cylinder must be double acting and include dual integral pilot-operated counterbalance valves to prevent cylinder collapse in case of hose failure. Cylinder must be fully retracted when in the transport mode to prevent exposure of cylinder rod to corrosive road salts.
Tilt Section Operation:	Loader must include a hydraulic lock-out device to prevent operation of the tilt section while loader is in the dumping mode.
Lift/Dump Cylinder:	Single 5-inch bore with 2-inch diameter rod cylinder. Cylinder must be double acting and include dual integral pilot-operated counterbalance valves to prevent cylinder collapse in case of hose failure.
Dump/Tilt Interlock:	Dumping must be accomplished through a rear pivot. Tilt and lift sections must lock into a rigid full length 25”-wide frame to provide support for the container while in the dump mode. These sections form this frame without the use of mechanical latches, which rely on gravity, springs, or container/body mounted latches. The system must be protected from out of sequence operation.
Rear Body Hold-Downs:	Dual fixed-position hold-down devices mounted to the dump frame to secure the body to the loader through all ranges of the dump mode. This must be accomplished without the use of steel springs and/or hydraulic/air cylinders. Loader must be compatible with containers manufactured to ANSI Z245.60 recommended standard for waste containers.
Rear Dump Hinge Pin:	2-inch diameter type 304 or 17-4 stainless steel minimum.
Pins:	All pins to be type 304 or 17-4 stainless steel.
Bushings:	All bushings are to be of the permanently lubricated variety.
Hoses & Hydraulic Fittings:	All hoses and fittings are to be SAE; metrics not allowed. O-ring face seal fittings to be utilized wherever possible.
Origin of Manufacture:	Loader to be designed and manufactured in the United States of America.

Base Assembly P/N 23832

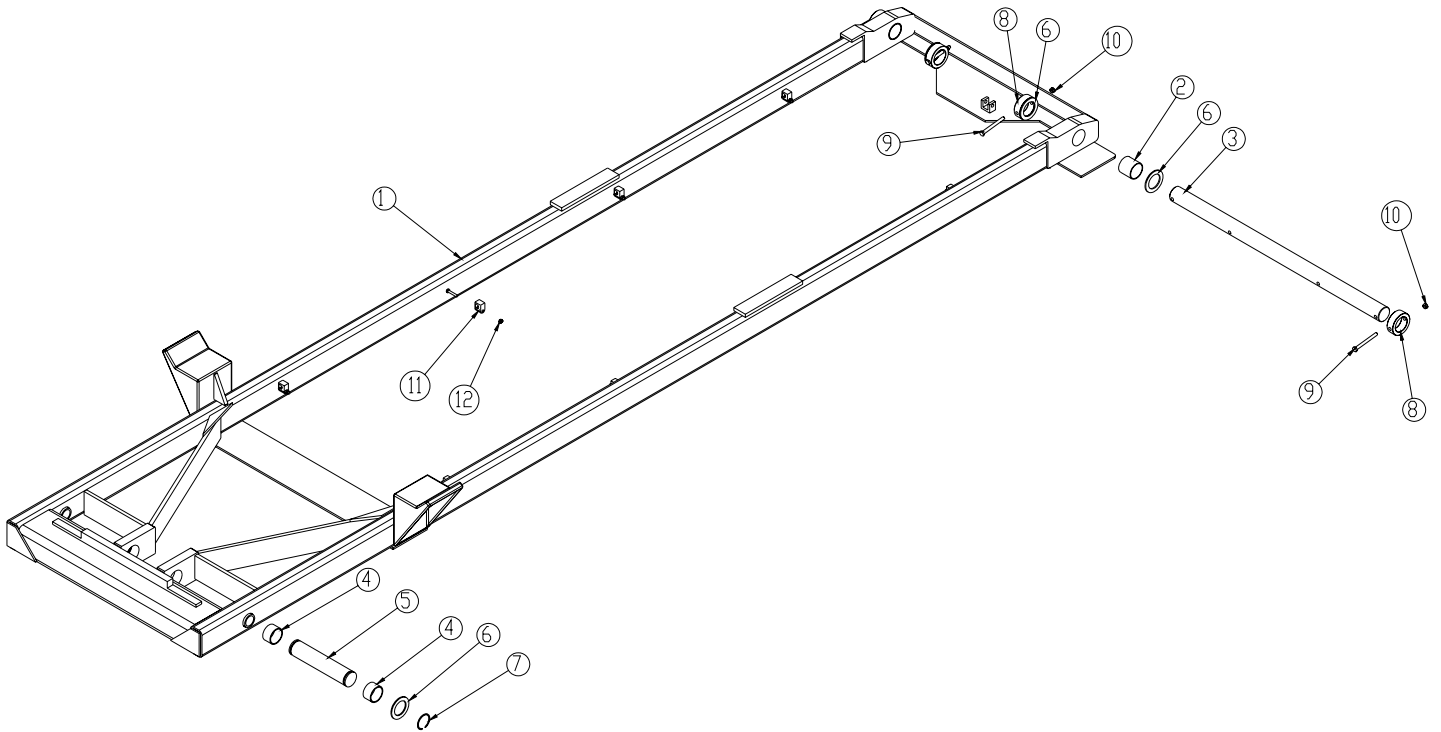

ITEM	PART	DESCRIPTION	QTY.
1	23712	BASE 120-14-20k	1
2	4381	BUSHING 32DXR32 2.00X2.00 GARLOCK	2
3	24617	PIN 2.00X36.44	1
4	23699	BUSHING 32DXR20 2.00X1.25	2
5	22220	PIN 2.00X9.75	1
6	0427	MACHY WASHER 2.00ID 10GA	6
7	0108	SNAP RING 2.00 7200-200	2
8	22764	COLLAR 2.01X3.00X1.00	4
9	0532	CAP SCR 0.38-16X3.75 HHGR5	4
10	0347	NUT 0.38-16 HH NYLOC	4
11	D1505	HOSE CLAMP LB3140PP	8
12	0333	NUT 0.25-20 HHGR5 NYLOC	8

Dump Assembly P/N 23833

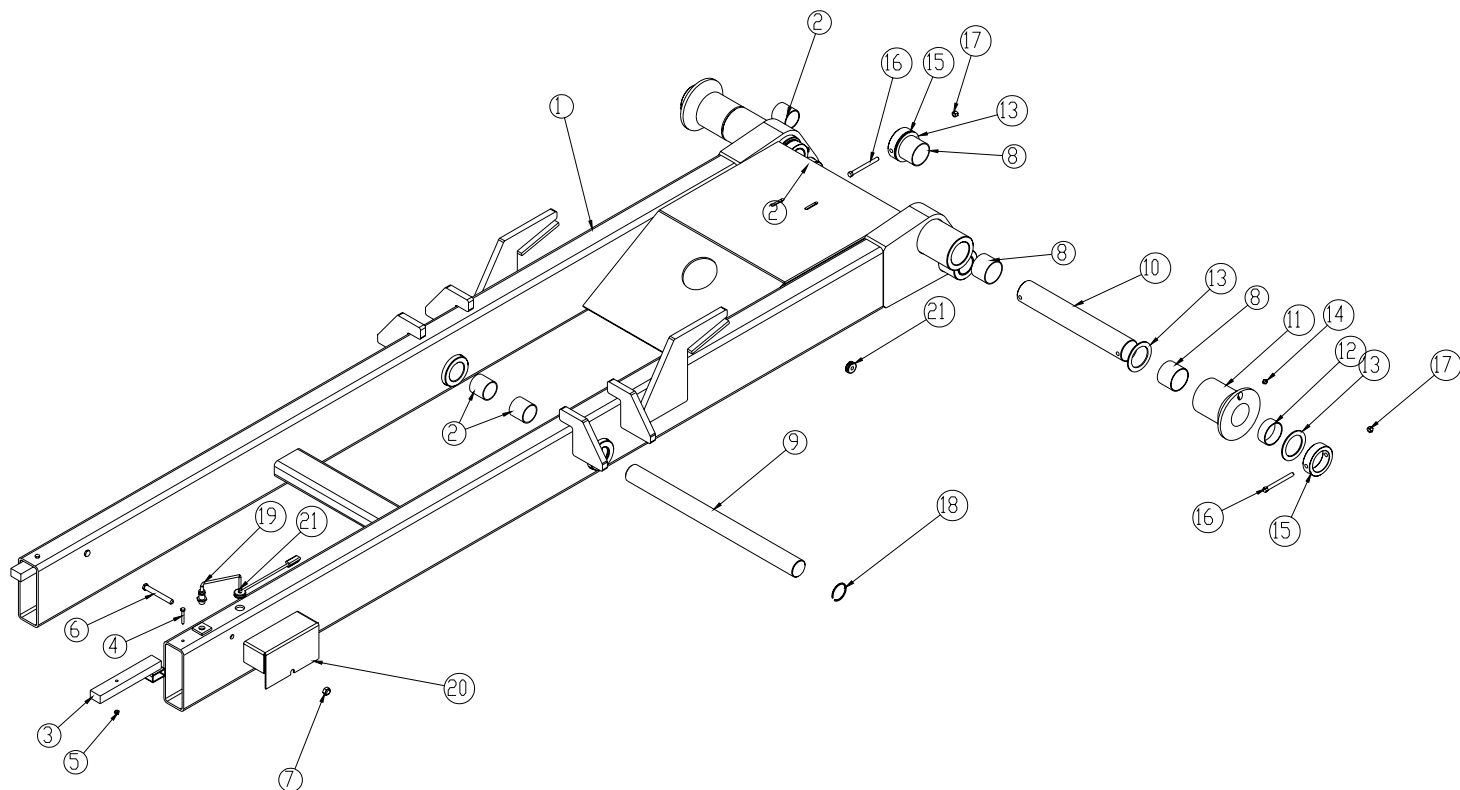

ITEM	PART	DESCRIPTION	QTY.
1	23714	DUMP 120-16-20K	1
2	4381	BUSHING 32DXR32 2.00X2.00 GARLOCK	6
3	23301	TAB LOADER BREAK AWAY	2
4	0332	CAP SCR 0.31-18X1.75 HHGR5	2
5	0333	NUT 0.25-20 HHGR5 NYLOC	2
6	0506	CAP SCR 0.50-13X4.00 HHGR5	2
7	C6106	NUT 0.50-13 HHGR5 NYLOC	2
8	0635	BUSHING 40DXR32 GARLOCK	6
9	22227	PIN 2.00X25.25	1
10	23931	PIN 2.50X17.38	2
11	21496	ROLLER 4" OD	2
12	13343	BUSHING 40DXR16 GARLOCK	2
13	1547	THRUST WASHER	6
14	c1592	ZERK 1/8 NPT STRAIGHT	2
15	23930	COLLAR 2.51X3.50X1.00	4
16	C0953	CAP SCR 0.38-16X4.00 HHGR5	4
17	0347	NUT 0.38-16 HH NYLOC	4
18	2257	SNAP RING INSIDE 2.00	2
19	26287	SWITCH PROXIMITY CARLO GAVAZZI	1
20	26290	COVER SWITCH PROXIMITY	1
21	26930	GROMMET 1.25ODX0.25X0.38ID	2

Secondary Assembly P/N 23845

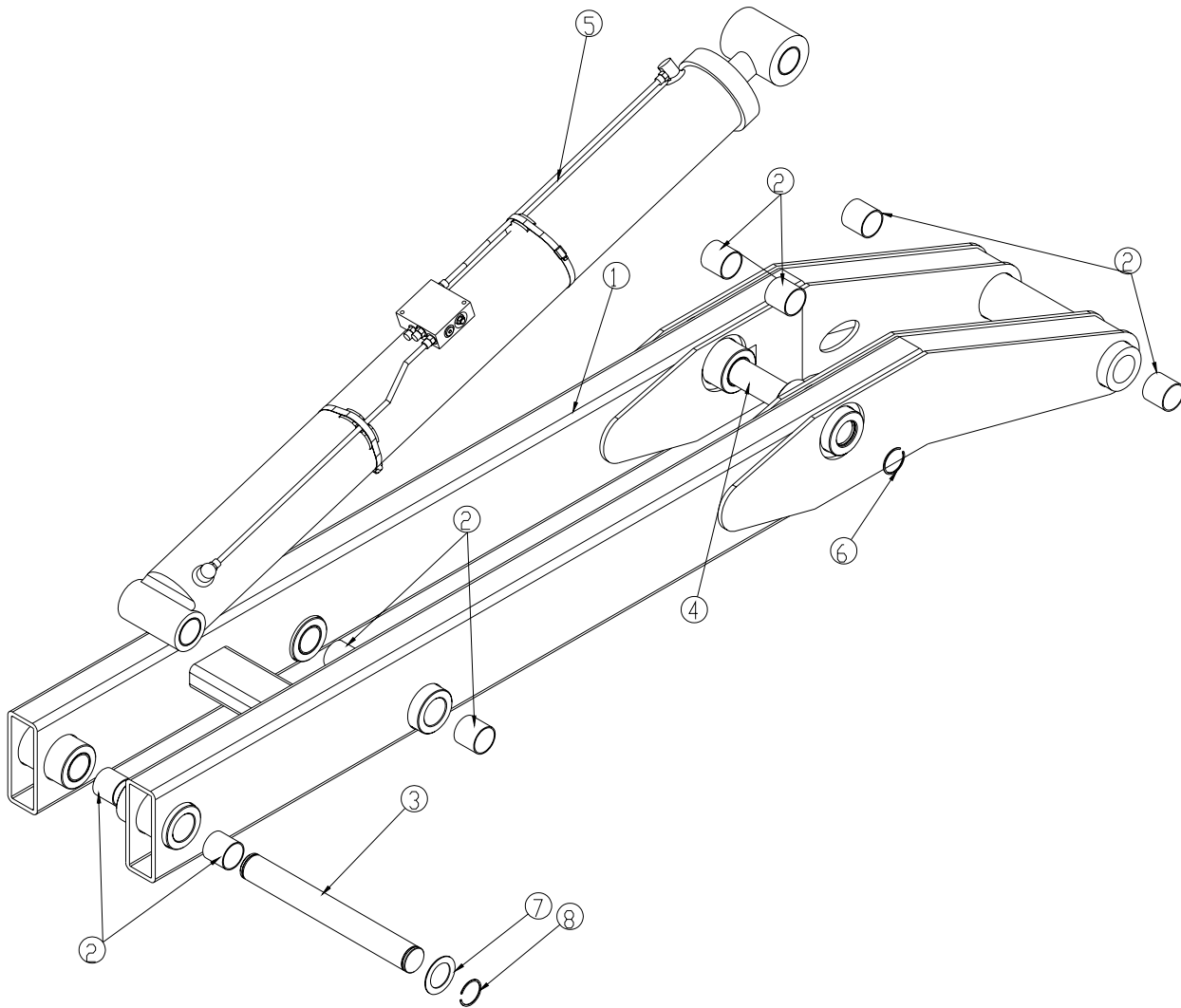

ITEM	PART	DESCRIPTION	QTY.
1	23844	SECONDARY 120-16-20K	1
2	4381	BUSHING 32DXR32 2.00X2.00 GARLOCK	14
3	0921	PIN 2.00X16.75	1
4	22286	PIN 2.00X16.00	1
5	19026	CYLINDER ASM 0079 STD	1
6	2257	SNAP RING INSIDE 2.00	2
7	0377	MACHY WASHER 2.00ID 14GA	2
8	0108	SNAP RING 2.00 7200-200	2

Tilt Assembly P/N 23707

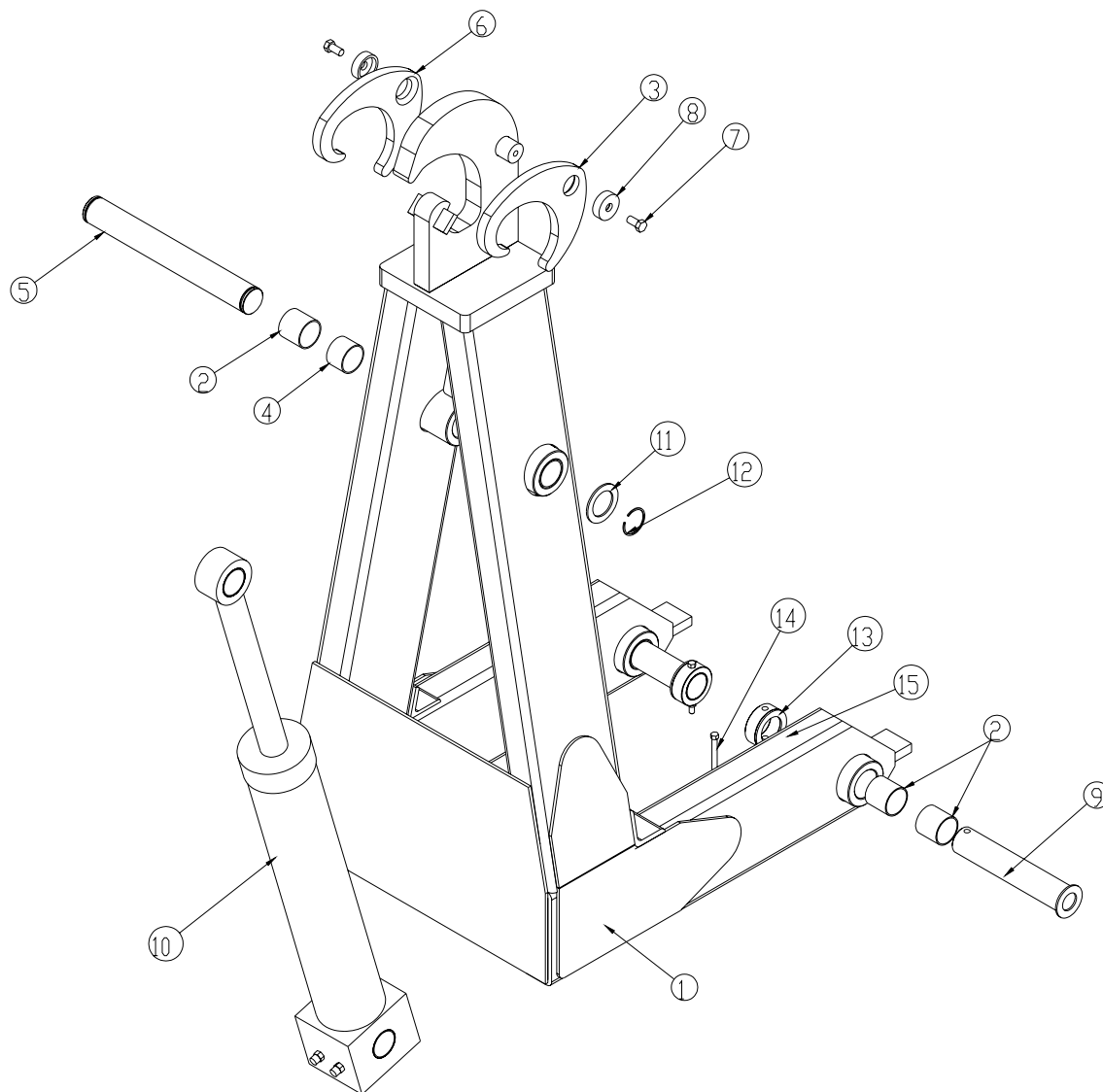

ITEM	PART	DESCRIPTION	QTY.
1	23583	TILT 108-11-20K	1
2	4381	BUSHING 32DXR32 2.00X2.00 GARLOCK	6
3	28765	LATCH SS 40000K	1
4	4380	BUSHING 32DXR24 2.00X1.50 GARLOCK	2
5	24249	PIN 2.00X15.88	1
6	28766	LATCH CS 40000K	1
7	8457	CAP SCR 0.50-13X1.00 SS	2
8	8818	PIN CAP 0.63X2.00X0.63 SS	2
9	24250	PIN 2.00X10.50 WLDMT	2
10	23159	CYLINDER ASM 4.00X14.50	1
11	0427	MACHY WASHER 2.00ID 10GA	4
12	0108	SNAP RING 2.00 7200-200	2
13	22764	COLLAR 2.01X3.00X1.00	2
14	C0953	CAP SCR 0.38-16X4.00 HHGR5	2
15	0347	NUT 0.38-16 HHGR5 NYLOC	2

Main Cylinder Assembly P/N 19026

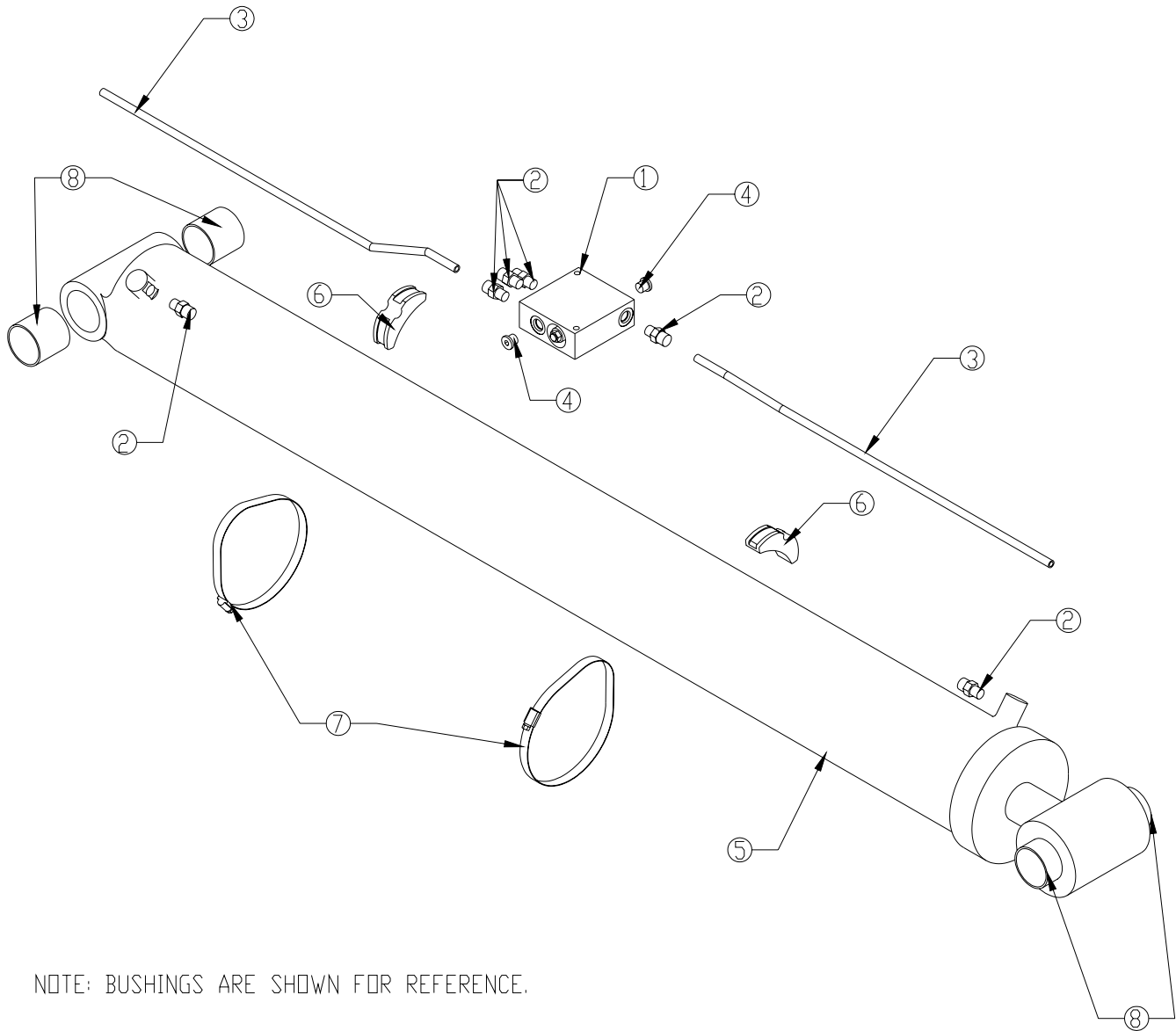

NOTE: BUSHINGS ARE SHOWN FOR REFERENCE.

ITEM	PART	DESCRIPTION	QTY.
1	15822	MANIFOLD ASM DUAL T11A 5000PSI	1
2	0279	FTG ADAPT 6-F5OLO-S	6
3	19027	TUBE ASM 0.38 X 23.16	2
4	C4961	PLUG STR HOLLOW HEX 0.38 6-HP5ON	2
5	0079	CYLINDER 5.00X52.38	1
6	18701	CLAMP PORT TUBE ZR518	2
7	19369	HOSE CLAMP 4.13-7.00 5416K38	2
8	4381	BUSHING 32DXR32 2.00X2.00 GARLOCK	4

Tilt Cylinder Assembly

P/N 23159

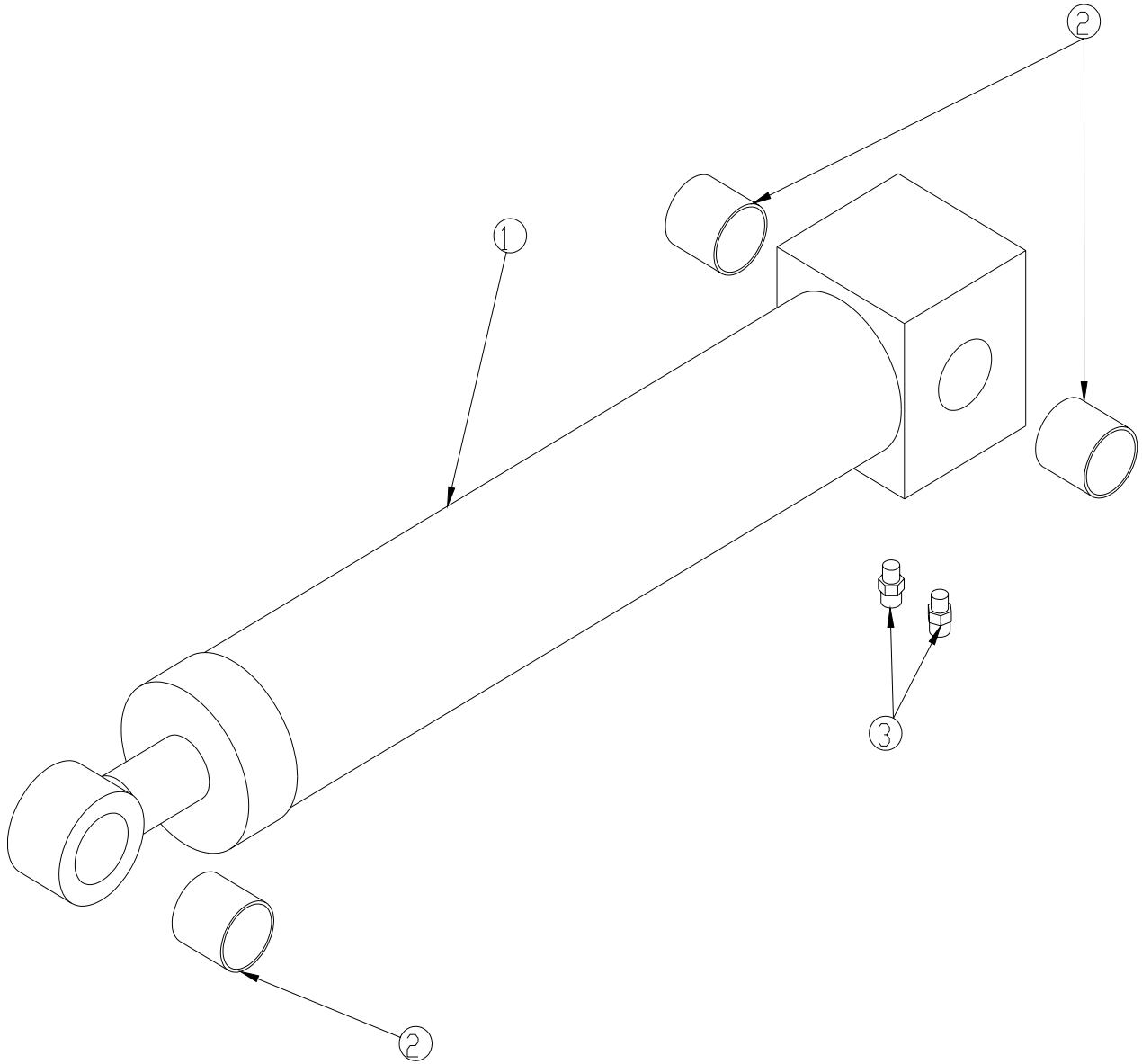

ITEM	PART	DESCRIPTION	QTY.
1	0907	CYLINDER 4.00X14.50	1
2	4381	BUSHING 32DXR32 2.00X2.00 GARLOCK	3
3	0279	FTG ADAPT 6-F5OLO-S	2

Installation Instructions

READ ALL INSTRUCTIONS BEFORE PROCEEDING

MOUNT PTO AND PUMP

MOUNT RESERVOIR VALVE COMBO TO TRUCK FRAME

CONNECT SUCTION AND PRESSURE TO TANK, VALVE BANK, AND PUMP

FILL OIL RESERVOIR TO THE SIGHT GLASS (MOBIL DTE 13M IS RECOMMENDED)

INSTALL CONTROLLERS AND CABLES IN CAB

SET SHUTTLE ON THE TRUCK SO THAT ITS FRONT PLATE IS AT LEAST 2" BEHIND THE CAB

SQUARE THE SHUTTLE ON THE TRUCK FRAME

PLACE A TIE DOWN CHANNEL ON THE TRUCK FRAME ON EACH SIDE OF THE REAR OF THE LOADER BELOW THE REAR MOUNTING FLANGE. MAKE SURE THERE ARE NO OBSTRUCTIONS ON THE TRUCK FRAME. DRILL A 11/16" HOLE THROUGH THE FRAME OF THE TRUCK ON EACH SIDE USING THE CHANNEL AS A TEMPLATE.

USING 5/8" BOLTS, WASHERS AND NUTS, BOLT THE CHANNELS TO THE TRUCK FRAME. USING THE CHANNELS AS A TEMPLATE, DRILL THROUGH THE MOUNTING FLANGE ON THE LOADER AND USE A 5/8" BOLT, FLAT WASHERS, AND LOCK NUT TO FASTEN THE LOADER TO THE CHANNELS

SHORTEN THE TRUCK FRAME TO ABOUT 2" FROM THE REAR TO THE LOADER

USING 5/8" BOLTS, WASHERS, AND NUTS FASTEN 2 TIE DOWN CHANNELS TOGETHER WITH THE NARROW FACES TOWARDS EACH OTHER, DO THIS WITH ALL 14 CHANNELS

PLACE THE TIE DOWN CHANNELS IN THE APPROXIMATE POSITIONS SHOWN ON PAGE 10, WITH THE TOP OF THE LOWER CHANNEL FLUSH TO THE TOP OF THE TRUCK FRAME (NOTE: FRONT TIE DOWNS **MUST** BE WITHIN 6 INCHES OF THE FRONT OF THE LOADER)

USING THE MOUNTING CHANNELS AS A GUIDE DRILL (4) 11/16" HOLES THROUGH THE TRUCK FRAME.

USING 5/8" BOLTS, WASHERS, AND NUTS SECURE ALL TIE DOWNS TO THE TRUCK FRAME

WELD THE UPPER TIE DOWNS TO LOADER BASE

CONNECT HOSES TO VALVE BANK AS INDICATED IN HYDRAULIC ASSEMBLY

SET THE RELIEF VALVE TO 4200 PSI

OPERATE THE LOADER TO ELIMINATE AIR FROM THE SYSTEM

CHECK THE OIL LEVEL AND ADD OIL IF REQUIRED

Mounting Kit P/N 2966

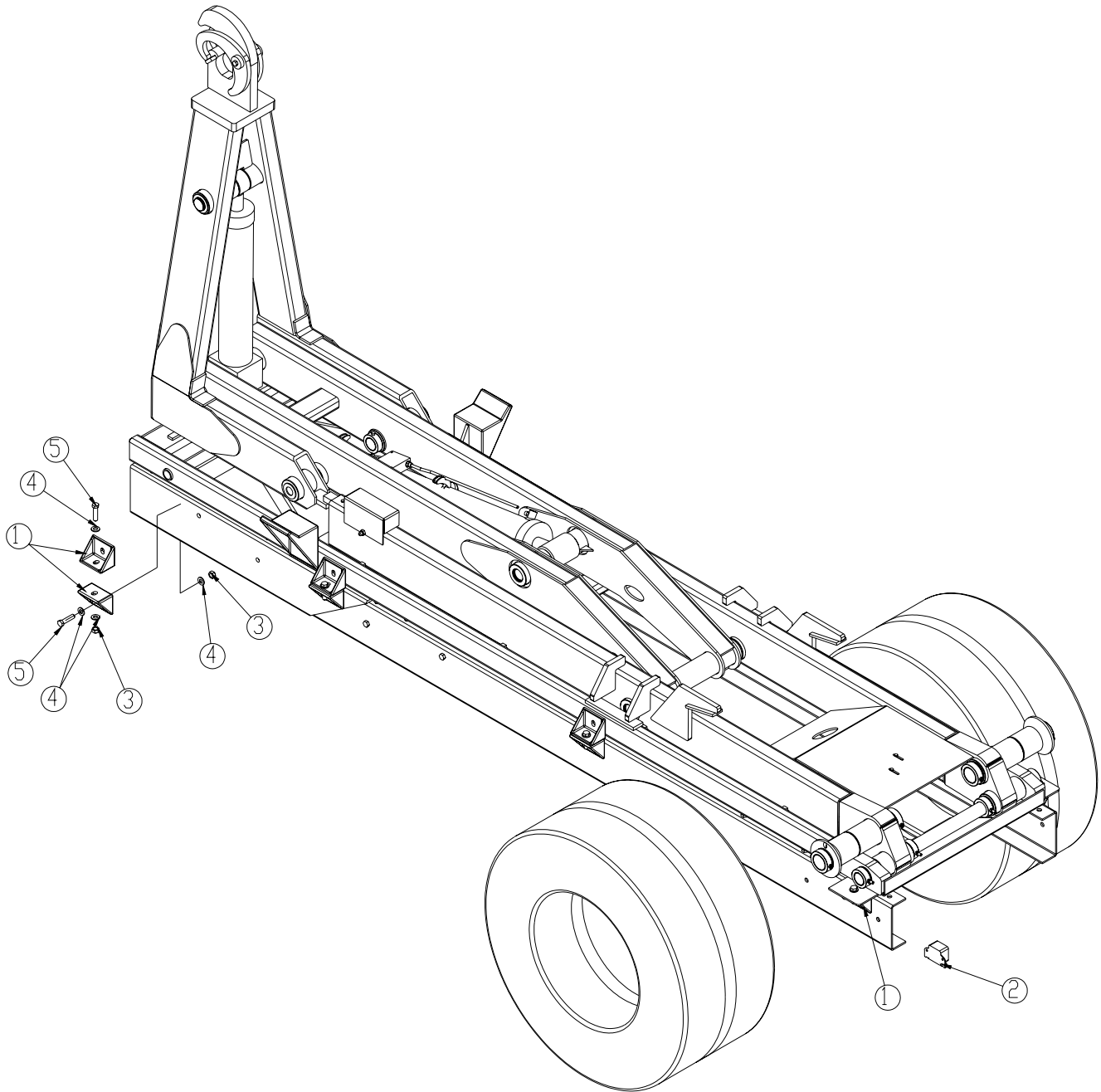

ITEM	PART	DESCRIPTION	QTY.
1	D0143	TIE DOWN CHANNEL	14
2	D0045	BACKUP ALARM .97 DECIBAL	1
3	24868	NUT 0.63-11 HH NYLOC	16
4	C5902	WASHER 0.63 SAE FLAT YELLOW GR8	32
5	C1026	CAP SCR 0.63-11X2.50 HHGR8 ZY	16

Rotary Valve Installation

P/N 22455

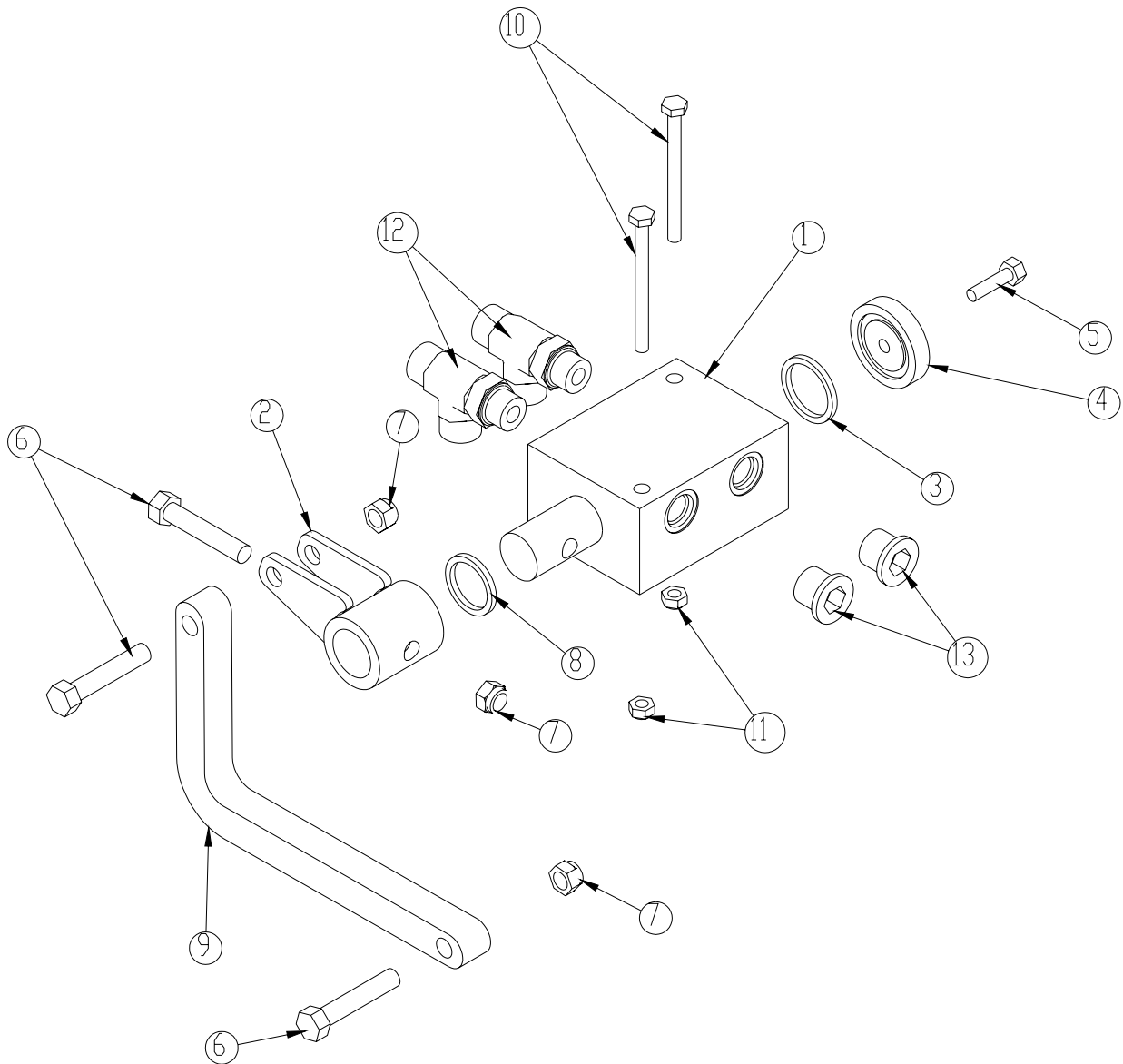

ITEM	PART	DESCRIPTION	QTY.
1	22456	ROTARY VALVE ASM	1
2	22450	WLDMT ROTARY VALVE ECCENTRIC	1
3	D1638	O'RING 1.12X1.38X0.12 568-216	1
4	3748	WASHER ROTARY VALVE	1
5	0480	CAP SCR 0.25-20X1.00 HHGR5	1
6	0353	CAP SCR 0.38-16X2.00 HHGR5	3
7	0347	NUT 0.38-16 HH NYLOC	3
8	0977	O'RING 1.00X1.25X0.12 568-214	1
9	22449	PLATE ROTARY VALVE ARM	1
10	0482	CAP SCR 0.25-20 X 3.00 HHGR5	2
11	0333	NUT 0.25-20 HHGR5 NYLOC	2
12	7350	FTG ST RUN TEE 8R5OLO	2
13	D1535	PLUG STR HOLLOW HEX 0.50 8-HP5ON	2

10 Gallon Hydraulic Assembly P/N 25629

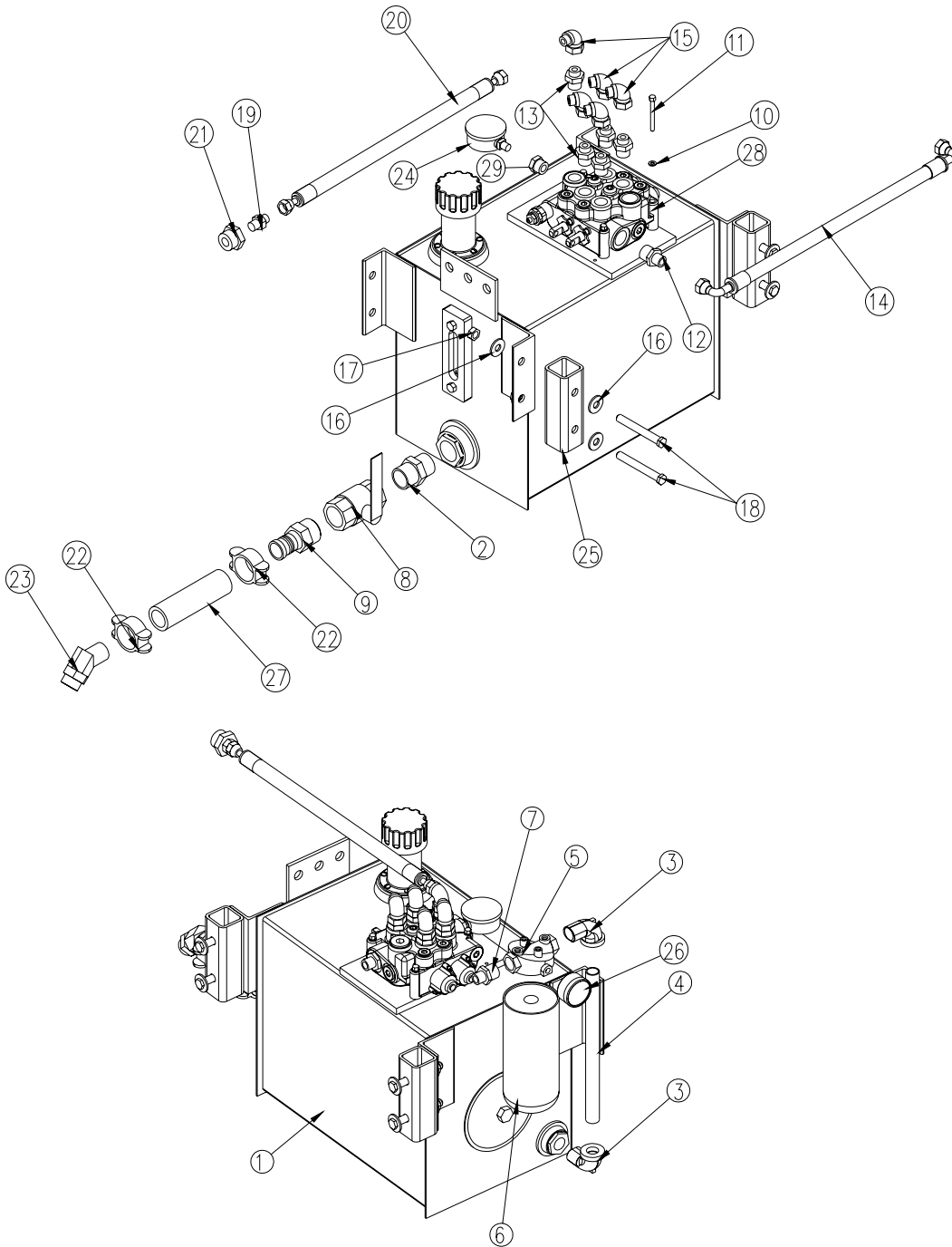

ITEM	PART	DESCRIPTION	QTY.	ITEM	PART	DESCRIPTION	QTY.
1	26455	RSRVR ASM 10GAL	1	16	0352	WASHER 0.50 USS FLAT ZINC	8
2	1115	FTG NIPPLE HEX MALE 0101-20-20	1	17	C6106	NUT 0.50-13 HHGR5 NYLOC	4
3	e2242	ST EL 0.75 90 DEG BLK	2	18	0506	CAP SCR 0.50-13X4.00 HHGR5	4
4	3320	NIPPLE 0.75X12.00 PIPE	1	19	C1854	FTG ADAPT 6-8 F5OLO-S	1
5	e6226	FILTER HEAD	1	20	14927	HOSE 0.38(381-JC-JC-6-6-6-120)	1
6	C6229	FILTER LARGE AE-10L	1	21	D0549	FTG ADAPT 16-8 F5OG5-S	1
7	C6014	FTG ADAPT 8-12 FOLO-S	1	22	C1123	HOSE CLAMP 88 DB-20	2
8	C5511	VALVE BALL 1.25	1	23	C4747	NIPPLE O'RING 45 4603-20-16	1
9	C2282	FTG 1.25 NPT TO 1.25 BARB	1	24	10094	GAUGE OIL LF 2.5" 0-500 BM	1
10	0521	WASHER 0.25 LOCK	3	25	9892	SPACER TANK MOUNTING 10 GAL	2
11	0339	CAP SCR 0.25-20X2.50 HHGR5	3	26	16145	GAUGE PRES FILTER SERVICE CI20	1
12	C1180	FTG ADAPT 8-12 F5OLO-S	1	27	17767	HOSE SUCT 1.25 10FT	1
13	C1855	FTG ADAPT 6-10 F5OLO-S	5	28	24611	VB S-SECTION VDM8	1
14	14826	HOSE 0.50(381-J9-J9-8-8-8-18-0)	1	29	25630	FTG ADAP 10-1/4 F5OG	1
15	C2248	FTG ADAPT 6-C6LO-S	5				

10 Gallon Tank Assembly P/N 26455

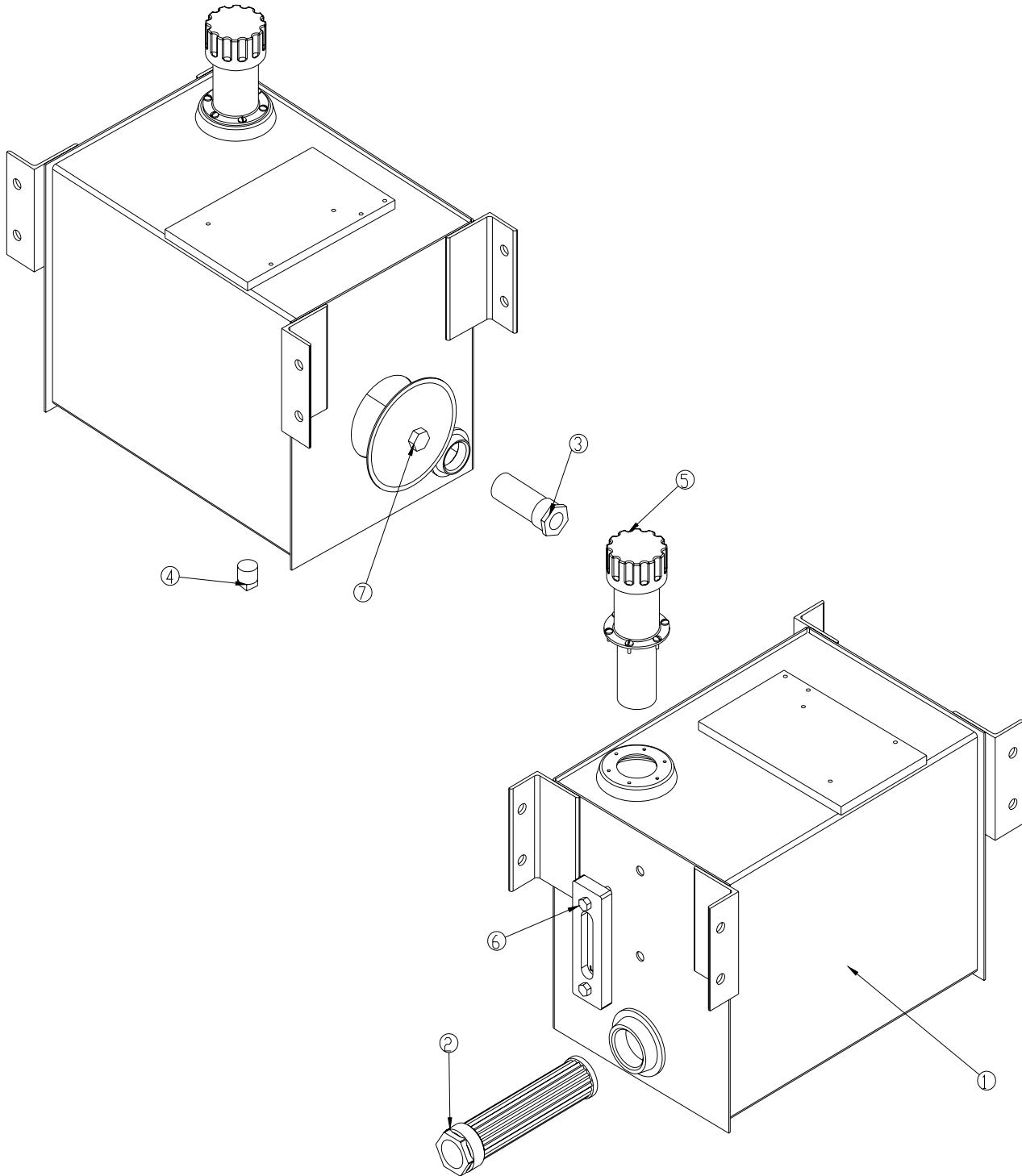

ITEM	PART	DESCRIPTION	QTY.
1	26501	RSRVR 10GAL K MODEL	1
2	C5552	FILTER STRAINER TFS-1220-0	1
3	C6326	DIFFUSER 5-17GAL	1
4	C2126	MAGNETIC PLUG DRAIN 3/4"	1
5	15462	CAP FILL ASM W/3" NECK	1
6	15463	THERMO SIGHT GAUGE	1
7	15464	TANK COVER	1

HOSE KIT P/N 14926

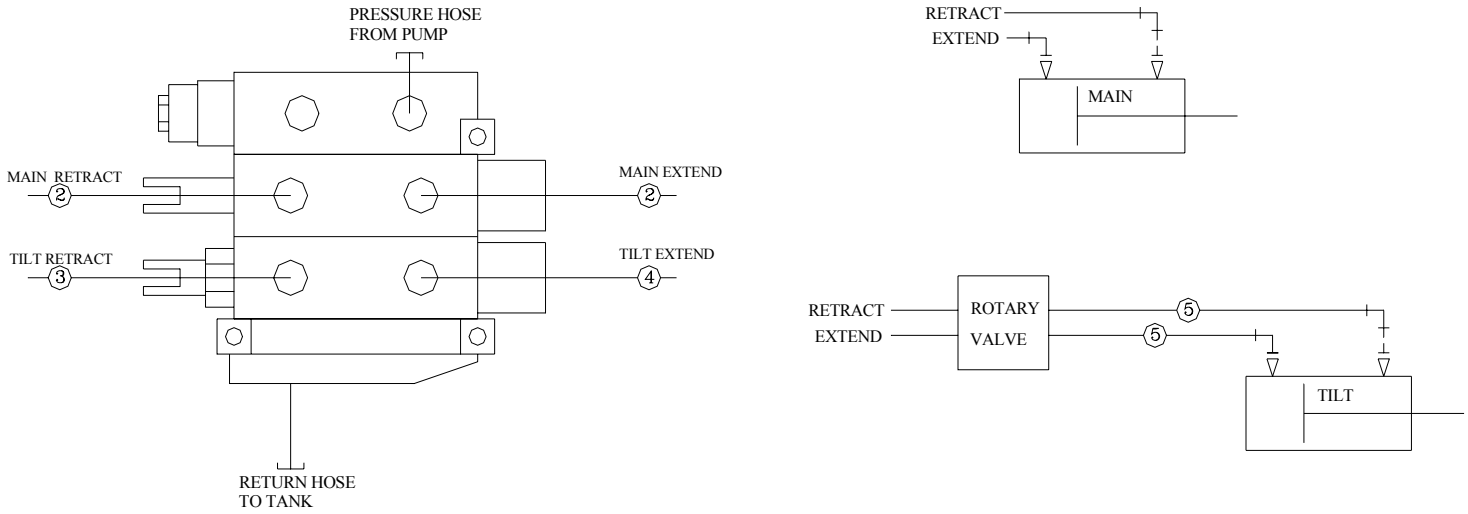

NOTE: IF RESERVOIR IS MOUNTED ON CS, HOSES 3 AND 4 ARE REVERSED

ITEM	PART	DESCRIPTION	QTY.
1	14926	HOSE KIT 120-16-16(ITEMS 2-5)	1
2	14827	HOSE 0.38X60.00	2ref
3	14830	HOSE 0.25X212.00	1ref
4	14829	HOSE 0.25X192.00	1ref
5	14828	HOSE 0.25X150.00	2ref

Controller Assembly P/N 26414

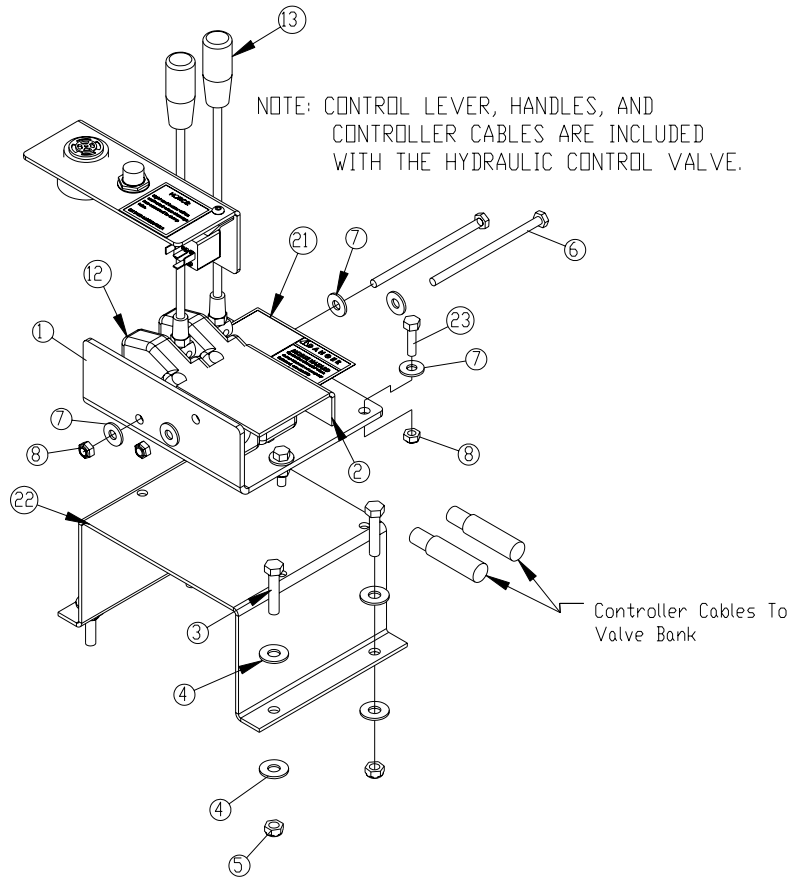

In Cab Installation

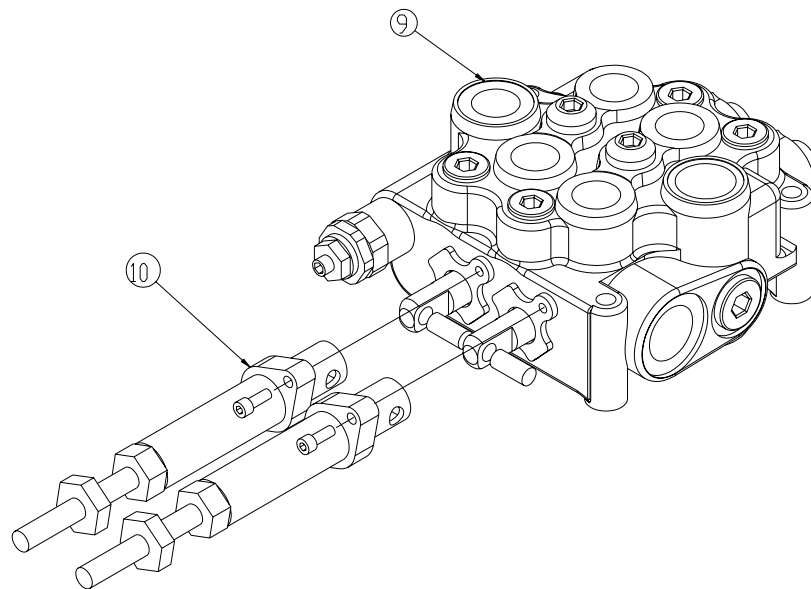

At Valve Installation

Controller Assembly Continued

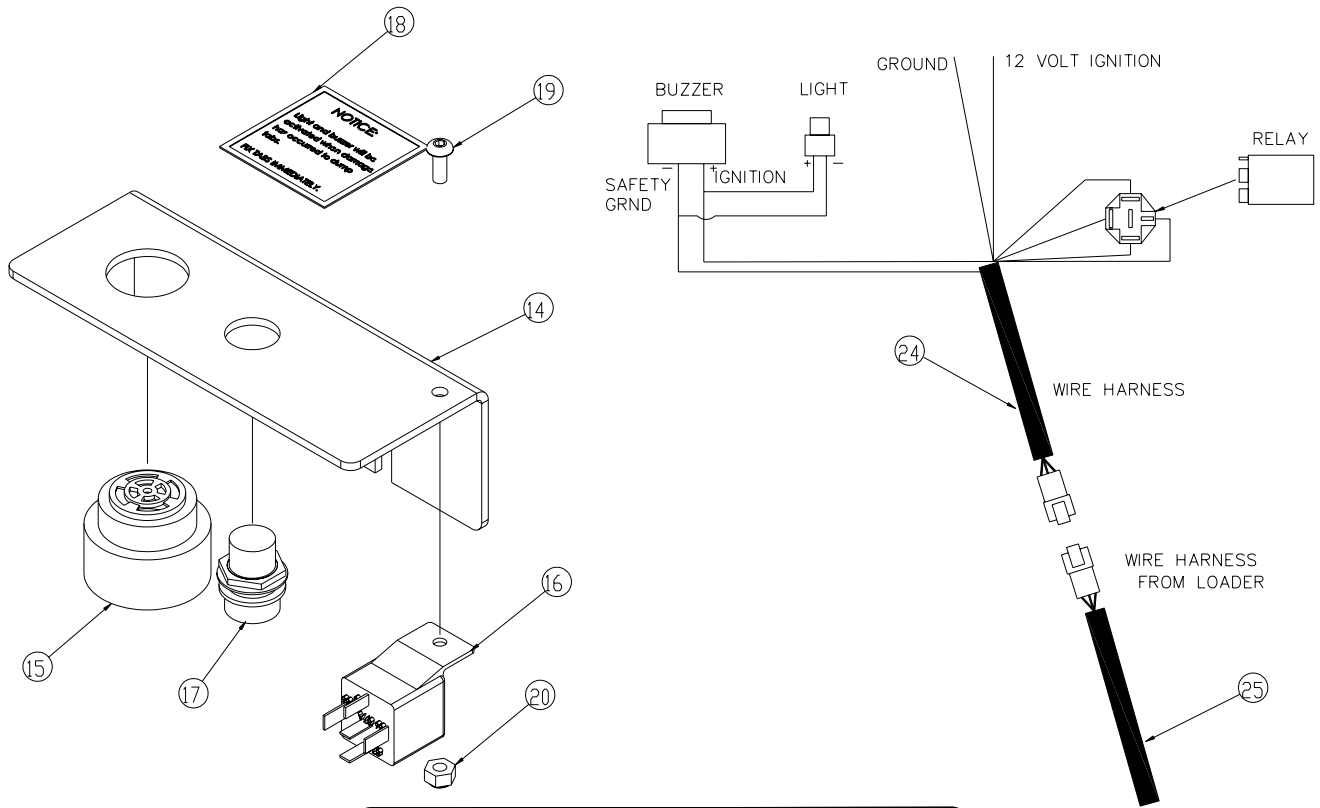

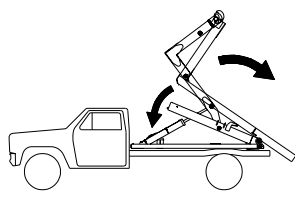

! DANGER

MISUSE HAZARD

Operation of loader when dump tabs are not properly fastened, can result in unexpected personal and equipment damage. Inspect tabs daily.

26134

Installation Instructions:

Connect the 12 Volt ignition wire to a key-on battery source.
 Hookup the wire harness in the cab to the wire harness from the loader
 Alarm will now sound when dump tabs have been damaged.

Tab Alarm Installation IS Required

ITEM	PART	DESCRIPTION	QTY.	ITEM	PART	DESCRIPTION	QTY.
1	25932	PLATE CONTROLLER MNT	1	14	26293	PLATE TAB ALARM MNT	1
2	25933	BRKT CONTROLLER DECAL	1	15	26031	BACKUP ALARM PIEZO JAMECO 123537	1
3	0486	CAP SCR 0.31-18X1.50 HHGR5	4	16	C6072	RELAY BOSCH 20-30 AMP	1
4	0343	WASHER 0.31 USS FLAT ZINC	8	17	26288	LIGHT INDICATOR RED FORCE PTO	1
5	0342	NUT 0.31-18 HH NYLOC	4	18	26135	DECAL NOTICE FIX TABS	1
6	0528	CAP SCR 0.25-20X4.50 HHGR5	2	19	D1711	CAP SCR #10-24X0.50 BTNHD SS	1
7	0340	WASHER 0.25 FLAT	8	20	26034	NUT #10-24 HH NYLOC	1
8	0333	NUT 0.25-20 HHGR5 NYLOC	6	21	26134	DECAL MISUSE HAZZARD	1
9	24611	VB 2-SECTION VDM8	1	22	18801	RISER AIR CONTROL	1
10	24620	CABLE HOOK UP KIT SALAMI	2	23	0480	CAP SCR 0.25-20X1.00 HHGR5	4
11	25935	CONTROL CABLE 16' SALAMI	1	24	26291	WIRE HARNESS TAB ALARM	1
12	24746	CONTROL LEVER SALAMI	2	25	26416	WIRE HARNESS PROXIMITY SWITCH 35FT	1
13	31512	HANDLE CONTROL LEVER SALAMI	2				

Decal Placement P/N D0779

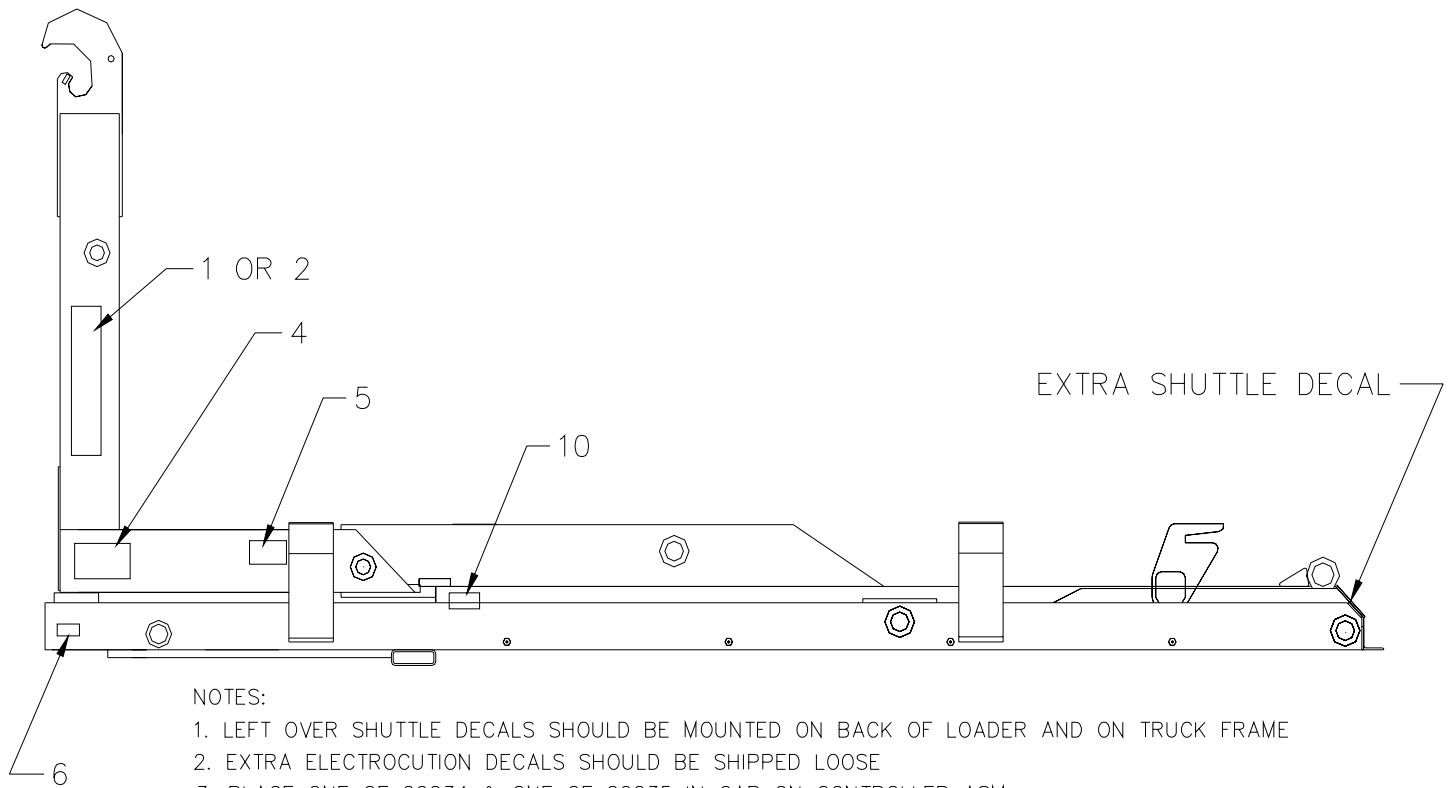

NOTES:

1. LEFT OVER SHUTTLE DECALS SHOULD BE MOUNTED ON BACK OF LOADER AND ON TRUCK FRAME
2. EXTRA ELECTROCUTION DECALS SHOULD BE SHIPPED LOOSE
3. PLACE ONE OF 26234 & ONE OF 26235 IN CAB ON CONTROLLER ASM
4. REPLACE SAFETY DECALS IF THEY BECOME WORN

* THESE DECALS NOT SHOWN(MOUNT IN CAB OR ON TRUCK FRAME)

ITEM	PART	DESCRIPTION	QTY.
1	C6208	DECAL SHUTTLE LARGE	2
2	C6207	DECAL SHUTTLE SMALL	2
*3	C4545	DECAL DANGER ELECTROCUTION	1
4	C1179	DECAL DANGER ELECTROCUTION HORTL	2
5	C0865	DECAL WARNING ARMS	2
6	4214	DECAL CONTACT STELLAR	1
*7	0651	DECAL OPERATION	1
*8	4190	DECAL DANGER OPERATION CONDITION	2
*9	C4540	DECAL DANGER	2
10	26134	DECAL DANGER MISUSE HAZARD	4
*11	26135	DECAL NOTICE FIX TABS	1

Subframe

Minimum recommended rail construction	
120-16-20	6x2x1/4

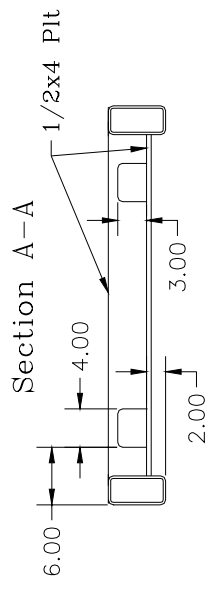
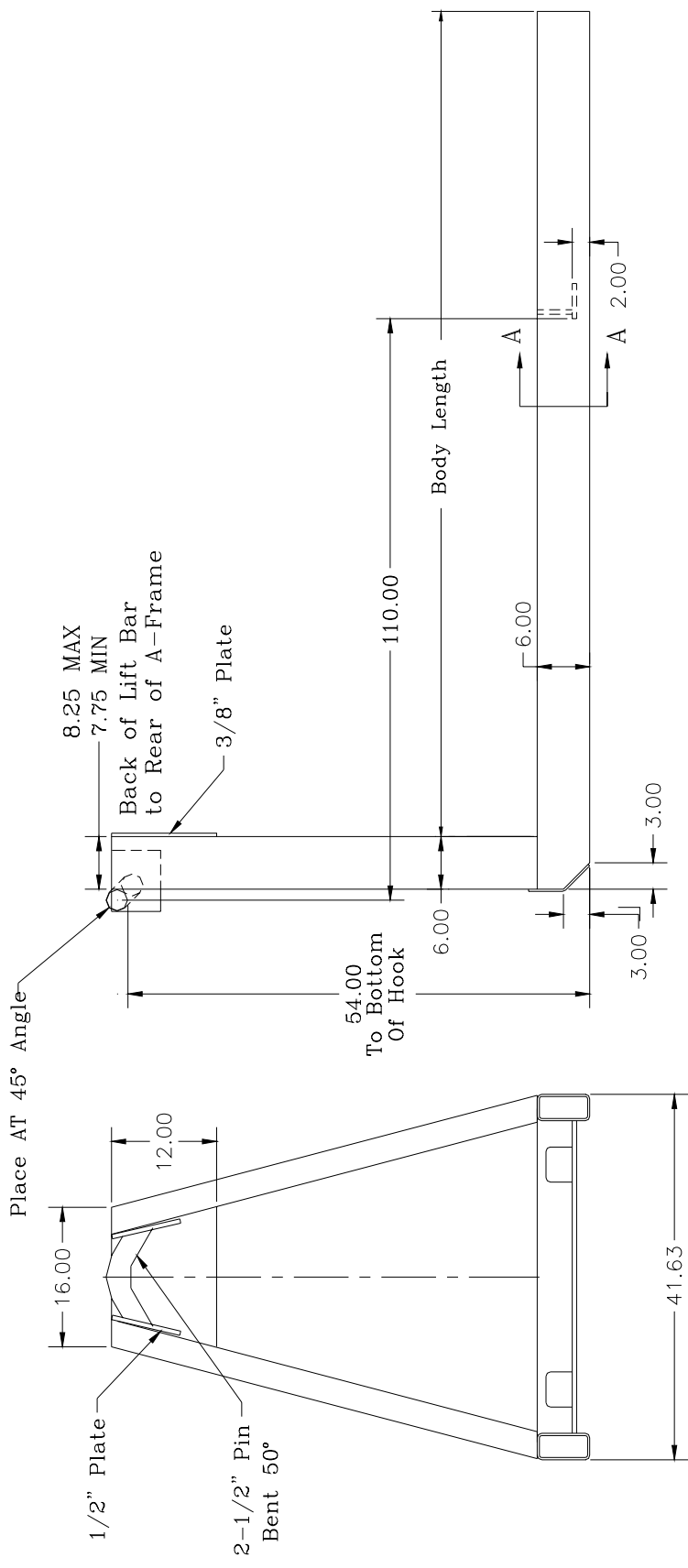

Note: Cap all tube ends.



Limited Warranty Statement

Stellar Industries, Inc. (Stellar) warrants products designed and manufactured by Stellar to be free from defects in material and workmanship under proper use and maintenance. Products must be installed and operated in accordance with Stellar's written instructions and capacities. The warranty period shall cover the following:

Twelve (12) month warranty on parts from the date recorded by Stellar as the in-service date, not to extend beyond twenty-four (24) months from date of manufacture,

Twelve (12) month repair labor from the date recorded by Stellar as the in-service date, not to extend beyond twenty-four (24) month from date of manufacture, and

Thirty-six (36) month warranty on all Stellar Crane and Hooklift structural parts from the date recorded by Stellar as the in-service date, not to extend beyond forty-eight (48) months from date of manufacture.

The in-service date will be derived from the completed warranty registration card. In the event a warranty registration card is not received by Stellar, the factory ship date will be used.

Stellar's obligation under this warranty is limited to, and the sole remedy for any such defect shall be, the repair and/or replacement (at Stellar's option) of the unaltered part and/or component in question. Stellar after-sales service personnel must be notified by telephone, fax, or letter of any warranty-applicable damage within fourteen (14) days of its occurrence. If at all possible, Stellar will ship the replacement part within 24-hours of notification by the most economical, yet expedient, means possible. Expedited freight delivery will be at the expense of the owner.

Warranty claims must be submitted and shall be processed in accordance with Stellar's established warranty claim procedure. Stellar after-sales service personnel must be contacted prior to any warranty claim. A return materials authorization (RMA) account number must be issued to the claiming party prior to the return of any warranty parts. Parts returned without prior authorization will not be recognized for warranty consideration. All damaged parts must be returned to Stellar freight prepaid; freight collect returns will be refused. Freight reimbursement of returned parts will be considered as part of the warranty claim.

Warranty service will be performed by any Stellar new equipment distributor, or by any Stellar-recognized service center authorized to service the type of product involved, or by the Stellar factory in the event of a direct sale. At the time of requesting warranty service, the owner must present evidence of date of delivery of the product. The owner shall be obligated to pay for any overtime labor requested of the servicing company by the owner, any field service call charges, and any towing and/or transportation charges associated with moving the equipment to the designated repair/service provider.

All obligations of Stellar and its authorized dealers and service providers shall be voided if someone other than an authorized Stellar dealer provides other than routine maintenance service without prior written approval from Stellar. In the case repair work is performed on a Stellar-manufactured product, original Stellar parts must be used to keep the warranty in force. The warranty may also be voided if the product is modified or altered in any way not approved, in writing, by Stellar.

The owner/operator is responsible for furnishing proof of the date of original purchase of the Stellar product in question. Warranty registration is the ultimate responsibility of the owner and may be accomplished by the completion and return of the Stellar product registration card provided with the product. If the owner is not sure of registration, he is encouraged to contact Stellar at the address below to confirm registration of the product in question. This warranty covers only defective material and workmanship. It does not cover depreciation or damage caused by normal wear and tear, accident, mishap, untrained operators, or improper or unintended use. The owner has the obligation of performing routine care and maintenance duties as stated in Stellar's written instructions, recommendations, and specifications. Any damage resulting from owner/operator failure to perform such duties shall void the coverage of this warranty. The owner will pay the cost of labor and supplies associated with routine maintenance.

The only remedies the owner has in connection with the breach or performance of any warranty on the Stellar product specified are those set above. In no event will Stellar, the Stellar distributor/dealer, or any company affiliated with Stellar be liable for business interruptions, costs of delay, or for any special, indirect, incidental, or consequential costs or damages. Such costs may include, but are not limited to, loss of time, loss of revenue, loss of use, wages, salaries, commissions, lodging, meals, towing, hydraulic fluid, or any other incidental cost.

All products purchased by Stellar from outside vendors shall be covered by the warranty offered by that respective manufacturer only. Stellar does not participate in, or obligate itself to, any such warranty.

Stellar reserves the right to make changes in design or improvement upon its products without imposing upon itself the same upon its products theretofore manufactured.

This warranty will apply to all Stellar Hooklifts, Stellar Service Trucks, & Truck-mounted Cranes shipped from Stellar's factory after July 1, 2005. The warranty is for the use of the original owner only and is not transferable without prior written permission from Stellar.

THIS WARRANTY IS EXPRESSLY IN LIEU OF ANY OTHER WARRANTIES, EXPRESS OR IMPLIED, INCLUDING ANY WARRANTY OF MERCHANTABILITY OR FITNESS FOR A PARTICULAR PURPOSE. REMEDIES UNDER THIS WARRANTY ARE LIMITED TO THE PROVISION OF MATERIAL AND SERVICES, AS SPECIFIED HEREIN. STELLAR INDUSTRIES, INC. IS NOT RESPONSIBLE FOR INCIDENTAL OR CONSEQUENTIAL DAMAGES.

Revision Date: February 2007

Document Number: 37040