

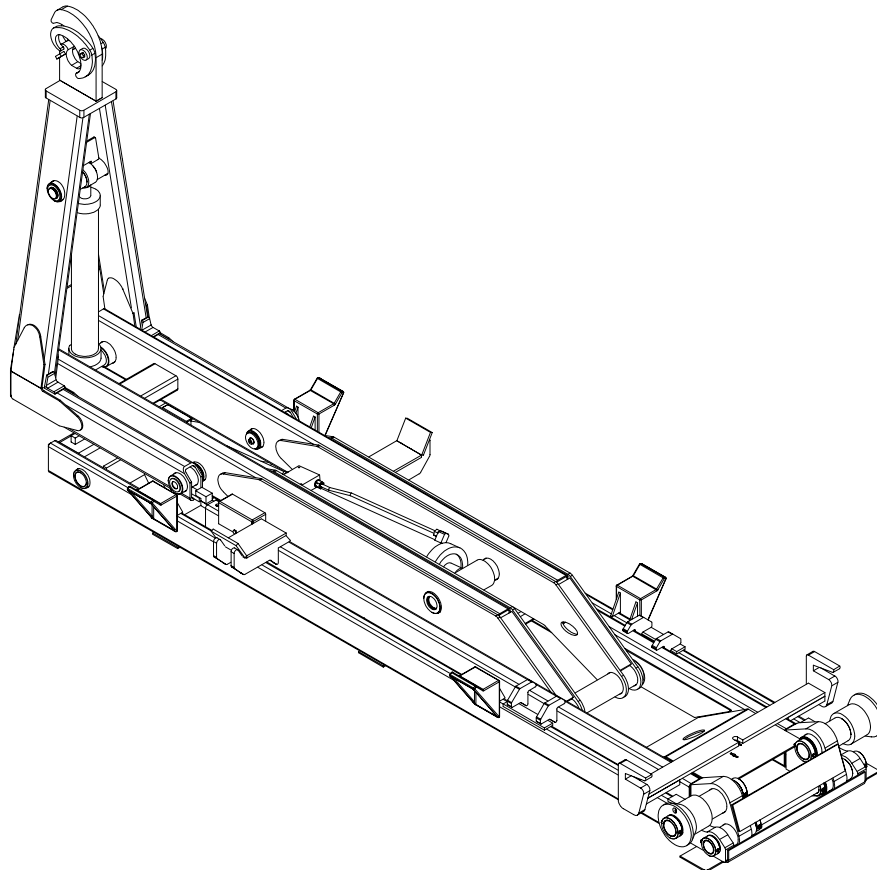

***STELLAR SHUTTLE***  
***MODEL 130-16-40K***  
***(P/N 28066)***  
***ASSEMBLY***  
***AND***  
***INSTALLATION***  
***MANUAL***



# Table of Contents

Hydraulic Hook Lift Specifications .....	2
Base Assembly .....	3
Dump Assembly .....	4
Secondary Assembly .....	5
Tilt Assembly .....	6
Main Cylinder Assembly.....	7
Tilt Cylinder Assembly .....	8
Installation Instructions .....	9
Mounting Kit.....	10
Rotary Valve Installation.....	11
25 Gallon Hydraulic Assembly .....	12
25 Gallon Tank Assembly.....	13
Hose Kit.....	14
Controller Assembly.....	15
Controller Assembly continued.....	16
Decal Placement .....	17
Subframe .....	18
Warranty.....	19

# Hydraulic Hook Lift Specifications

<b>Lifting Capacity:</b>	40,000 pounds gross weight evenly distributed in, or on, body.
<b>Container Length:</b>	14-foot through 17-foot from front A-frame to rear of skid rails. Longer bodies up to 19 feet may be accommodated if full dump angle is not required (may require special body-mounted or extendable truck-mounted bumper and additional latches to meet the Federal Motor Carrier Safety Administration (FMCSA) Rear End Protection regulation 393.86 and Securing Hook lift Containers regulation 393.134).
<b>Maximum Dump Angle:</b>	54°
<b>Operating Pressure:</b>	4200 PSI maximum.
<b>Weight of Loader:</b>	Loader weight not to exceed 4,100 pounds.
<b>Height of Loader:</b>	Loader height not to exceed 11.31” as measured from top of truck frame to top of loader rollers.
<b>Hook Height:</b>	61.75-inches from bottom of skid rails to centerline of hook bar. Loader must be able to pick up 10-inches below grade when mounted on a 41” truck frame height.
<b>Hydraulic Pump:</b>	Direct-coupled high-pressure gear pump.
<b>Hydraulic Control Valve:</b>	Hydraulic valve mounted directly onto the oil reservoir.
<b>Controls:</b>	Dual manual levers with sealed cable actuators mounted in the truck cab to allow full feathering of all loader functions.
<b>Tilting Hook Assembly:</b>	Loader must have pivoting type front tilt section (jib) to provide a low degree loading/unloading angle. Hook to include automatic mechanical safety latch, which disengages only when the container/body is in proper position to be picked up or dropped off.
<b>Tilt Cylinder:</b>	Single 4-inch bore with 2-inch diameter rod cylinder. Cylinder must be double acting and include dual integral pilot-operated counterbalance valves to prevent cylinder collapse in case of hose failure. Cylinder must be fully retracted when in the transport mode to prevent exposure of cylinder rod to corrosive road salts.
<b>Tilt Section Operation:</b>	Loader must include a hydraulic lock-out device to prevent operation of the tilt section while loader is in the dumping mode.
<b>Lift/Dump Cylinder:</b>	Single 7-inch bore with 3-inch diameter rod cylinder. Cylinder must be double acting and include dual integral pilot-operated counterbalance valves to prevent cylinder collapse in case of hose failure.
<b>Dump/Tilt Interlock:</b>	Dumping must be accomplished through a rear pivot. Tilt and lift sections must lock into a rigid full length 26” wide frame with front saddles to provide support for the container while in the dump mode. These sections form this frame without the use of mechanical latches, which rely on gravity, springs, or container/body mounted latches. The system must be protected from out of sequence operation.
<b>Rear Body Hold-Downs:</b>	Dual fixed-position hold-down devices mounted to the dump frame to secure the body to the loader through all ranges of the dump mode. This must be accomplished without the use of steel springs and/or hydraulic/air cylinders. Loader must be compatible with containers manufactured to ANSI Z245.60 recommended standard for waste containers.
<b>Rear Dump Hinge Pin:</b>	2-1/2-inch diameter type 304 or 17-4 stainless steel minimum
<b>Pins:</b>	All pins to be type 304 or 17-4 stainless steel.
<b>Bushings:</b>	All bushings are to be of the permanently lubricated variety.
<b>Hoses &amp; Hydraulic Fittings:</b>	All hoses and fittings are to be SAE: metrics not allowed. O-ring face seal fittings to be utilized wherever possible.
<b>Origin of Manufacture:</b>	Loader to be designed and manufactured in the United States of America.

# Base Assembly P/N 28057

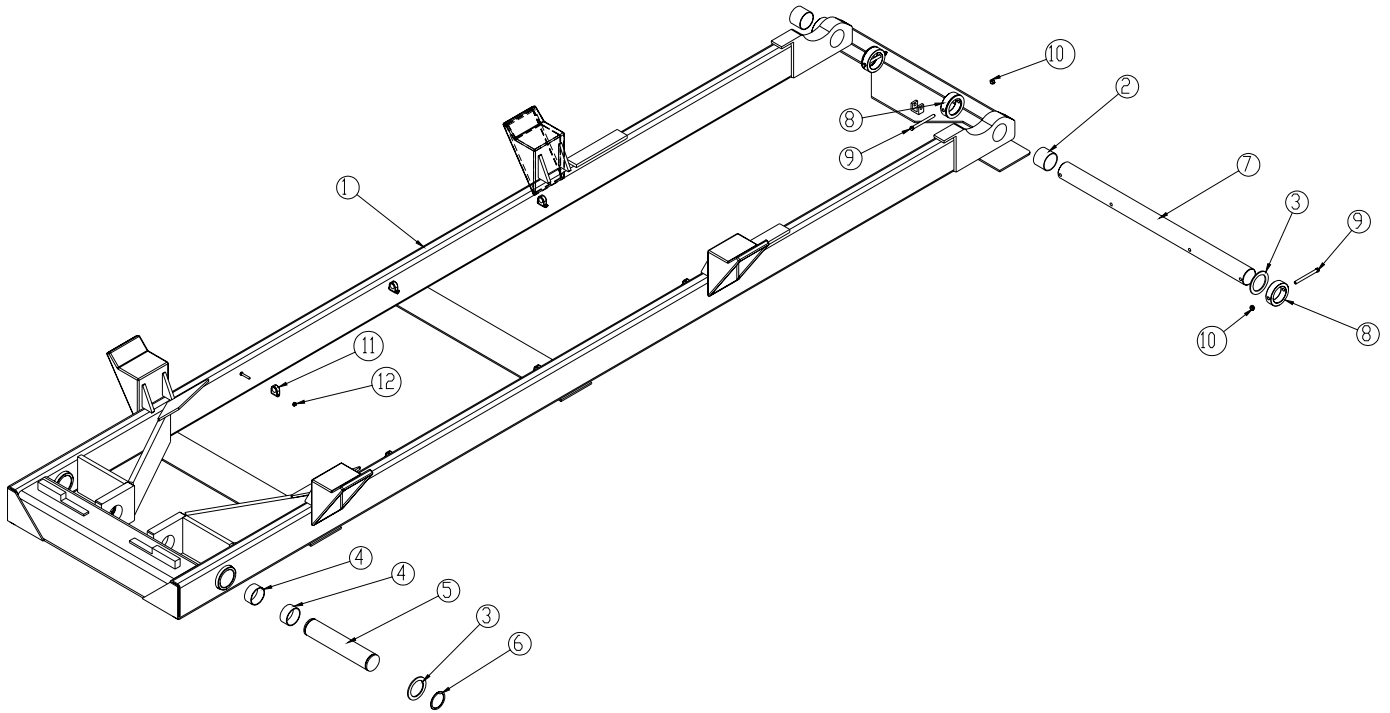

ITEM	PART	DESCRIPTION	QTY.
1	28058	BASE 130-16-32K	1
2	0635	BUSHING 40DXR32 GARLOCK	2
3	1593	MACHY WASHER 2.50ID 10GA	6
4	25574	BUSHING 40DXR20 2.50X1.25	2
5	0857	PIN 2.50X12.38	1
6	0636	SNAP RING 2.50 HD	2
7	26048	PIN 2.50X36.44	1
8	23930	COLLAR 2.51X3.50X1.00	4
9	32086	CAP SCR 0.38-16X4.25 HHGR5	4
10	0347	NUT 0.38-16 HH NYLOC	4
11	0337	HOSE CLAMP LN 4190 PP	6
12	0333	NUT 0.25-20 HHGR5 NYLOC	6

## Dump Assembly P/N 28060

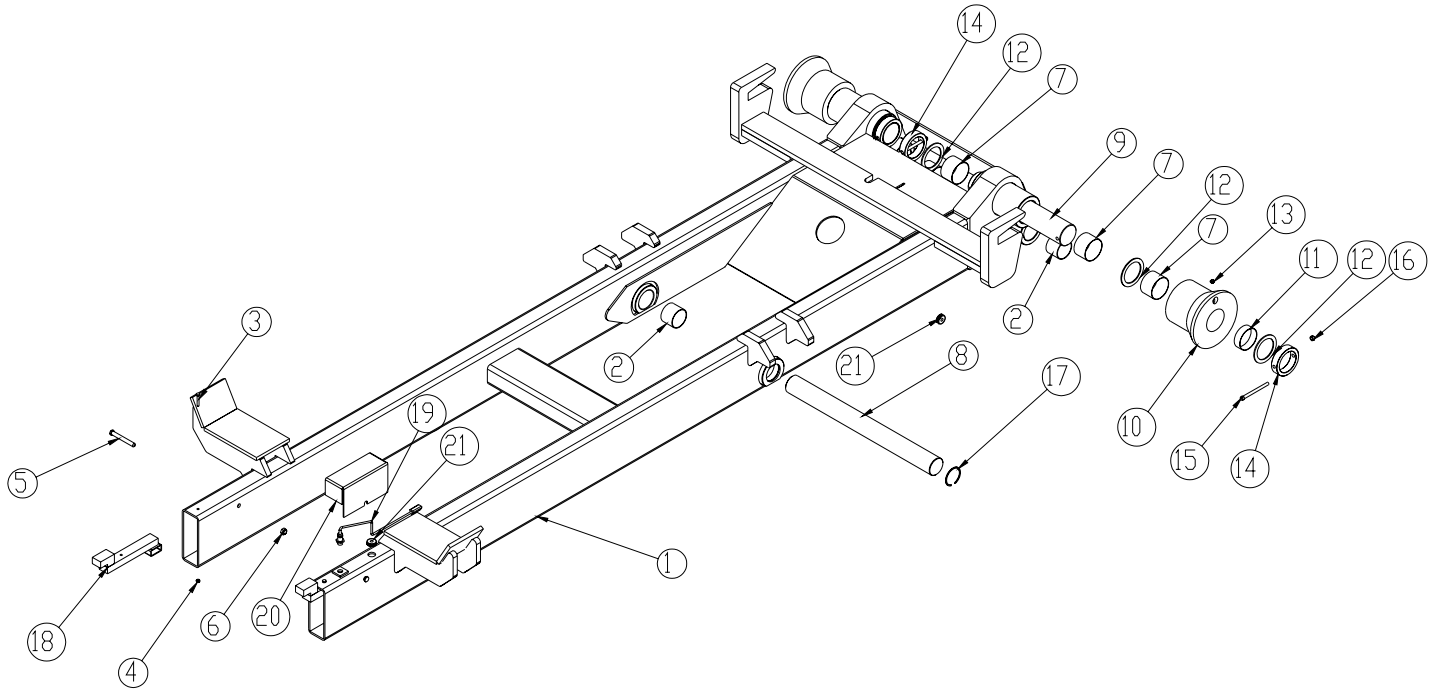

ITEM	PART	DESCRIPTION	QTY.
1	28061	DUMP 130-16-32K	1
2	0635	BUSHING 40DXR32 GARLOCK	6
3	0332	CAP SCR 0.31-18X1.75 HHGR5	2
4	0333	NUT 0.25-20 HHGR5 NYLOC	2
5	0506	CAP SCR 0.50-13X4.00 HHGR5	2
6	C6106	NUT 0.50-13 HHGR5 NYLOC	2
7	0865	BUSHING 48DXR32 GARLOCK	6
8	27376	PIN 2.50X26.25	1
9	26167	PIN 2.50X17.38	2
10	22432	ROLLER 52000# W/GREASE ZERK	2
11	13344	BUSHING 48DXR32 GARLOCK	2
12	1548	THRUST WASHER 3.01DIA UHMW .12 THK	6
13	c1592	ZERK 1/8 NPT STRAIGHT	2
14	26168	COLLAR 3.01X4.00X1.00	4
15	C0954	CAP SCR 0.38-16X4.50 HHGR5	4
16	0347	NUT 0.38-16 HH NYLOC	4
17	22216	SNAP RING INSIDE 2.50	2
18	26187	TAB LOADER BREAK AWAY	2
19	26287	SWITCH PROXIMITY CARLO GAVAZZI	1
20	26290	COVER SWITCH PROXIMITY	1
21	26930	GROMMET 1.25ODX0.25X0.38ID	2

## Secondary Assembly P/N 26574

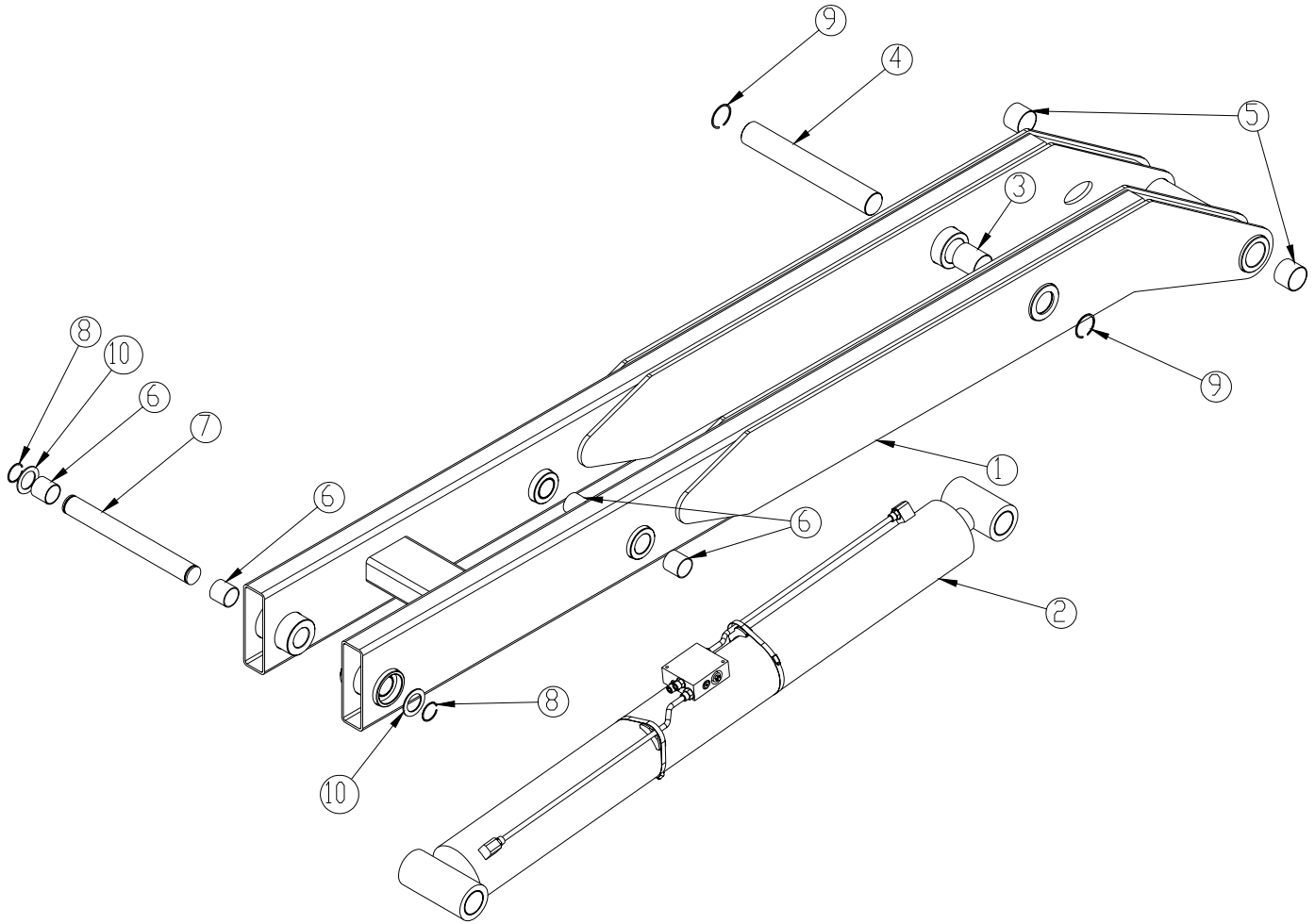

ITEM	PART	DESCRIPTION	QTY.
1	26389	SECONDARY 138-18-32K	1
2	31243	CYLINDER ASM 31242 7.00x57.50	1
3	5739	BUSHING 40DXR48 GARLOCK	2
4	26378	PIN 2.50X17.75	1
5	0635	BUSHING 40DXR32 GARLOCK	2
6	4381	BUSHING 32DXR32 2.00X2.00 GARLOCK	8
7	30243	PIN 2.00X17.75	1
8	0108	SNAP RING 2.00 7200-200	2
9	22216	SNAP RING INSIDE 2.50	2
10	1546	THRUST WASHER 2.01DIA UHMW .12THK	2

## Tilt Assembly P/N 26064

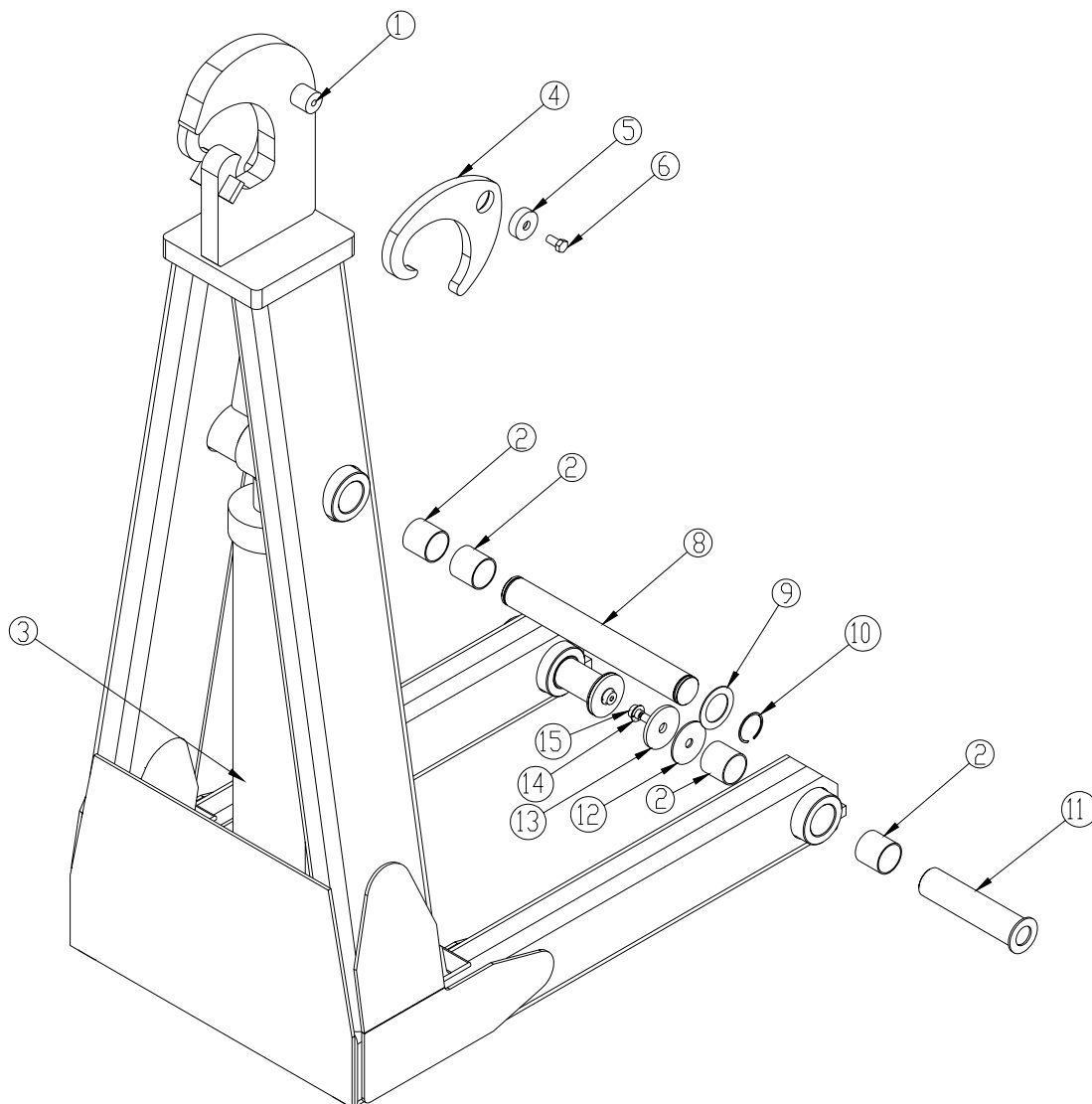

ITEM	PART	DESCRIPTION	QTY.
1	26065	TILT 108-14-32K	1
2	4381	BUSHING 32DXR32 2.00X2.00 GARLOCK	8
3	23456	CYLINDER ASM 4.00X24.50	1
4	0812	LATCH 40,000#	1
5	8818	PIN CAP 0.63X2.00X0.63	2
6	8457	CAP SCR 0.50-13X1.00 SS	2
7	2293	LATCH CS 40,000#	1
8	24249	PIN 2.00X15.88	1
9	0377	MACHY WASHER 2.00ID 10GA	2
10	0108	SNAP RING 2.00 7200-200	2
11	27768	PIN WLDMT 2.00X9.38 D&T	2
12	12719	THRUST WASHER 0.64x3.00x0.125	2
13	8454	PIN CAP 0.69x3.00x0.25 SS	2
14	12711	THRUST WASHER 0.63 DIA	2
15	12673	CAP SCREW 0.50-13 SHOULDER	2

# Main Cylinder Assembly

## P/N 31243

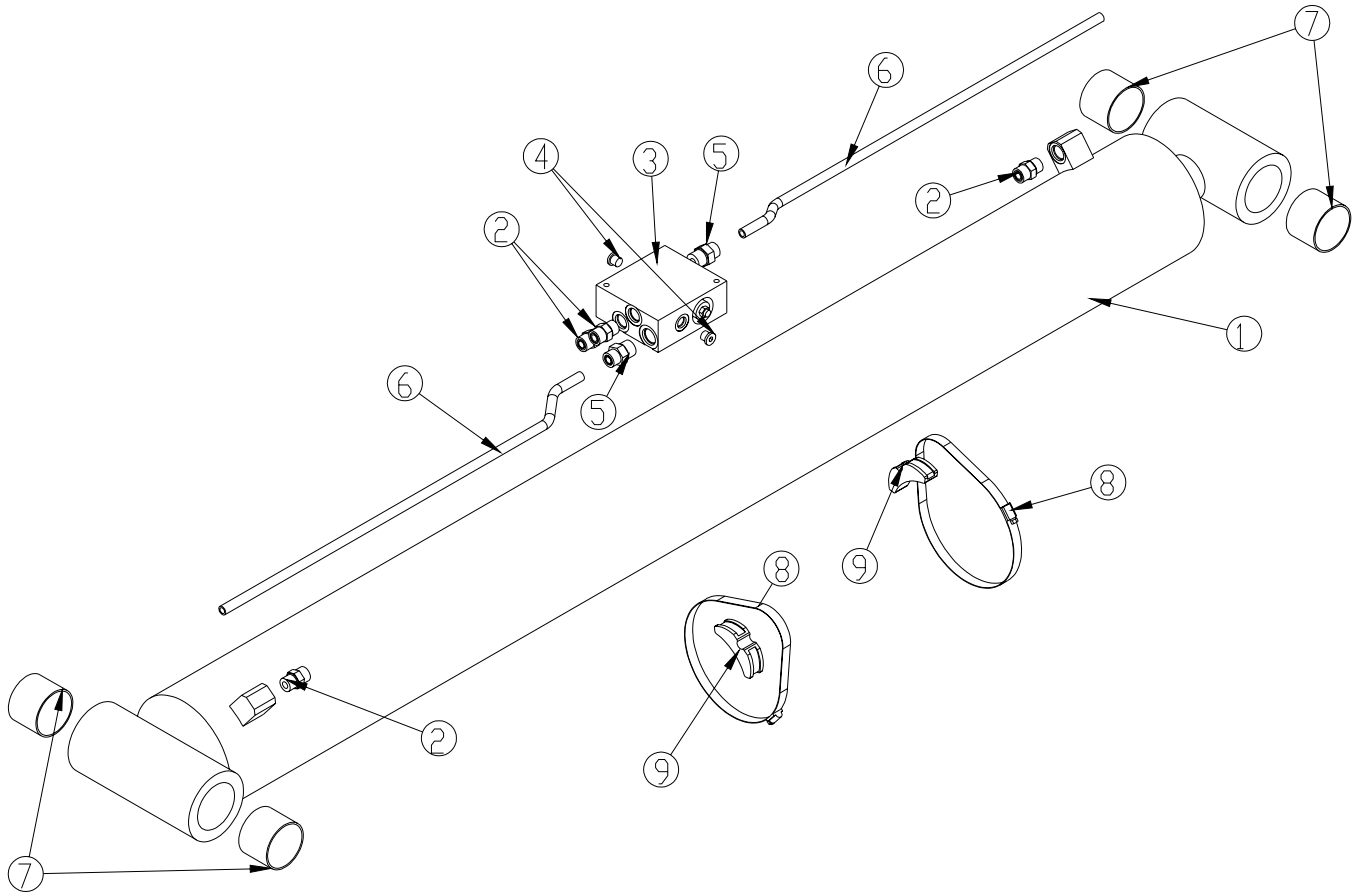

ITEM	PART	DESCRIPTION	QTY.
1	31242P	CYLINDER 31242 7.00X57.50 PAINT	1
2	1554	FTG ADAPT 8-F5OLO-S	4
3	15995	MANIFOLD ASM DUAL T2A 5000PSI	1
4	0280	PLUG SAE #6 05HP-6	2
5	C2252	FTG ADAPT 8-10-F5OLO-S	2
6	19867	TUBE ASM 0.50 X 27.25	2
7	0635	BUSHING 40DXR32 GARLOCK	4
8	19370	HOSE CLAMP 5.63-8.50 5416K39	2
9	18701	CLAMP PORT TUBE ZR518	2

# Tilt Cylinder Assembly

## P/N 23456

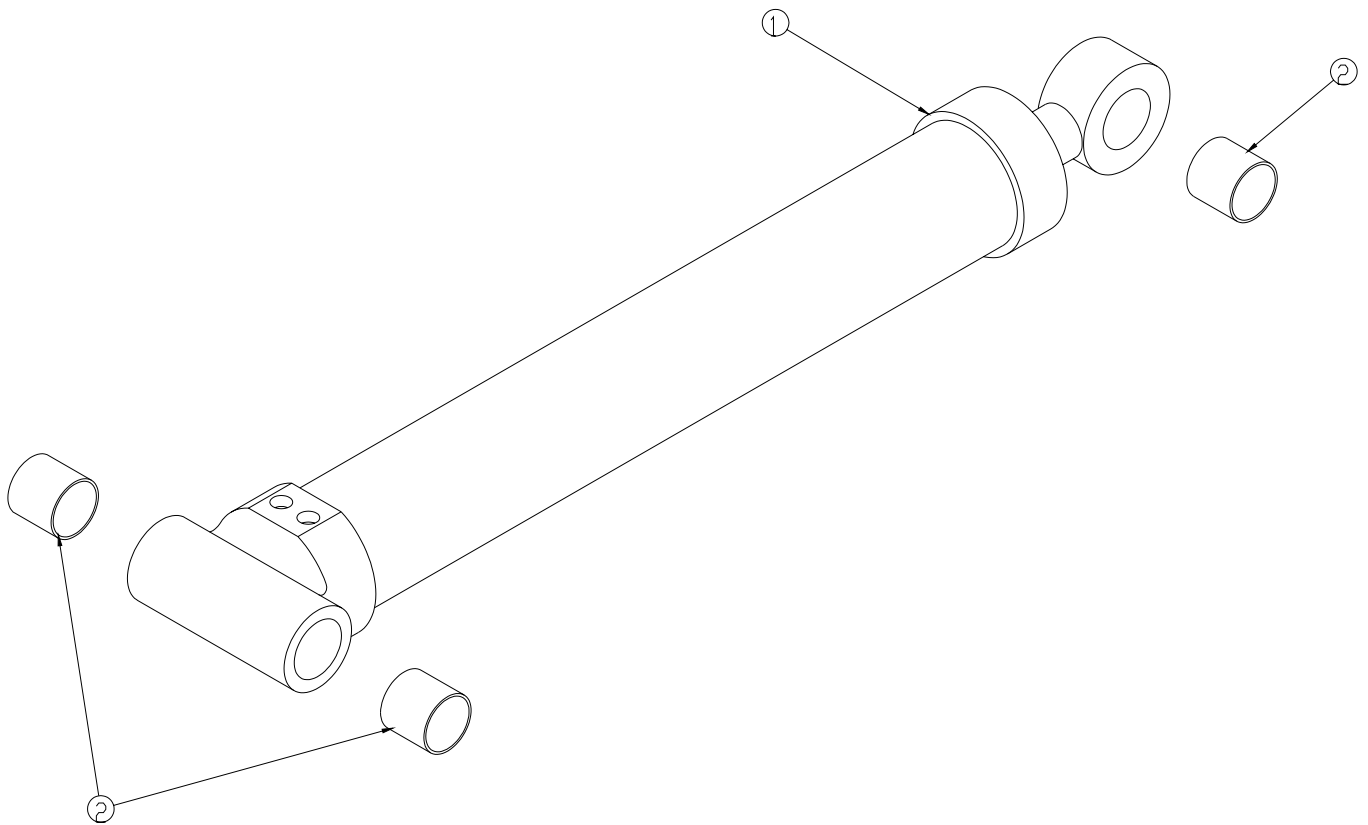

ITEM	PART	DESCRIPTION	QTY.
1	1748	CYLINDER 3.00X17.00	1
2	4381	BUSHING 32DXR32 2.00X2.00 GARLOCK	3

## **Installation Instructions**

### **READ ALL INSTRUCTIONS BEFORE PROCEEDING**

MOUNT PTO AND PUMP

MOUNT RESERVOIR VALVE COMBO TO TRUCK FRAME

CONNECT SUCTION AND PRESSURE TO TANK, VALVE BANK, AND PUMP

FILL OIL RESERVOIR TO THE SIGHT GLASS (MOBIL DTE 13M IS RECOMMENDED)

INSTALL CONTROLLERS AND CABLES IN CAB

SET SHUTTLE ON THE TRUCK SO THAT ITS FRONT PLATE IS AT LEAST 2" BEHIND THE CAB

SQUARE THE SHUTTLE ON THE TRUCK FRAME

PLACE A TIE DOWN CHANNEL ON THE TRUCK FRAME ON EACH SIDE OF THE REAR OF THE LOADER BELOW THE REAR MOUNTING FLANGE. MAKE SURE THERE ARE NO OBSTRUCTIONS ON THE TRUCK FRAME. DRILL A 11/16" HOLE THROUGH THE FRAME OF THE TRUCK ON EACH SIDE USING THE CHANNEL AS A TEMPLATE.

USING 5/8" BOLTS, WASHERS AND NUTS, BOLT THE CHANNELS TO THE TRUCK FRAME. USING THE CHANNELS AS A TEMPLATE, DRILL THROUGH THE MOUNTING FLANGE ON THE LOADER AND USE A 5/8" BOLT, FLAT WASHERS, AND LOCK NUT TO FASTEN THE LOADER TO THE CHANNELS

SHORTEN THE TRUCK FRAME TO ABOUT 2" FROM THE REAR TO THE LOADER

USING 5/8" BOLTS, WASHERS, AND NUTS FASTEN 2 TIE DOWN CHANNELS TOGETHER WITH THE NARROW FACES TOWARDS EACH OTHER, DO THIS WITH ALL 8 CHANNELS

PLACE THE TIE DOWN CHANNELS IN THE APPROXIMATE POSITIONS SHOWN ON PAGE 10, WITH THE TOP OF THE LOWER CHANNEL FLUSH TO THE TOP OF THE TRUCK FRAME (NOTE: FRONT TIE DOWNS **MUST** BE WITHIN 6 INCHES OF THE FRONT OF THE LOADER)

USING THE MOUNTING CHANNELS AS A GUIDE DRILL (4) 11/16" HOLES THROUGH THE TRUCK FRAME.

USING 5/8" BOLTS, WASHERS, AND NUTS SECURE ALL TIE DOWNS TO THE TRUCK FRAME

WELD THE UPPER TIE DOWNS TO LOADER BASE

CONNECT HOSES TO VALVE BANK AS INDICATED IN HYDRAULIC ASSEMBLY

SET THE RELIEF VALVE TO 4200 PSI

OPERATE THE LOADER TO ELIMINATE AIR FROM THE SYSTEM

CHECK THE OIL LEVEL AND ADD OIL IF REQUIRED

# Mounting Kit P/N 16898

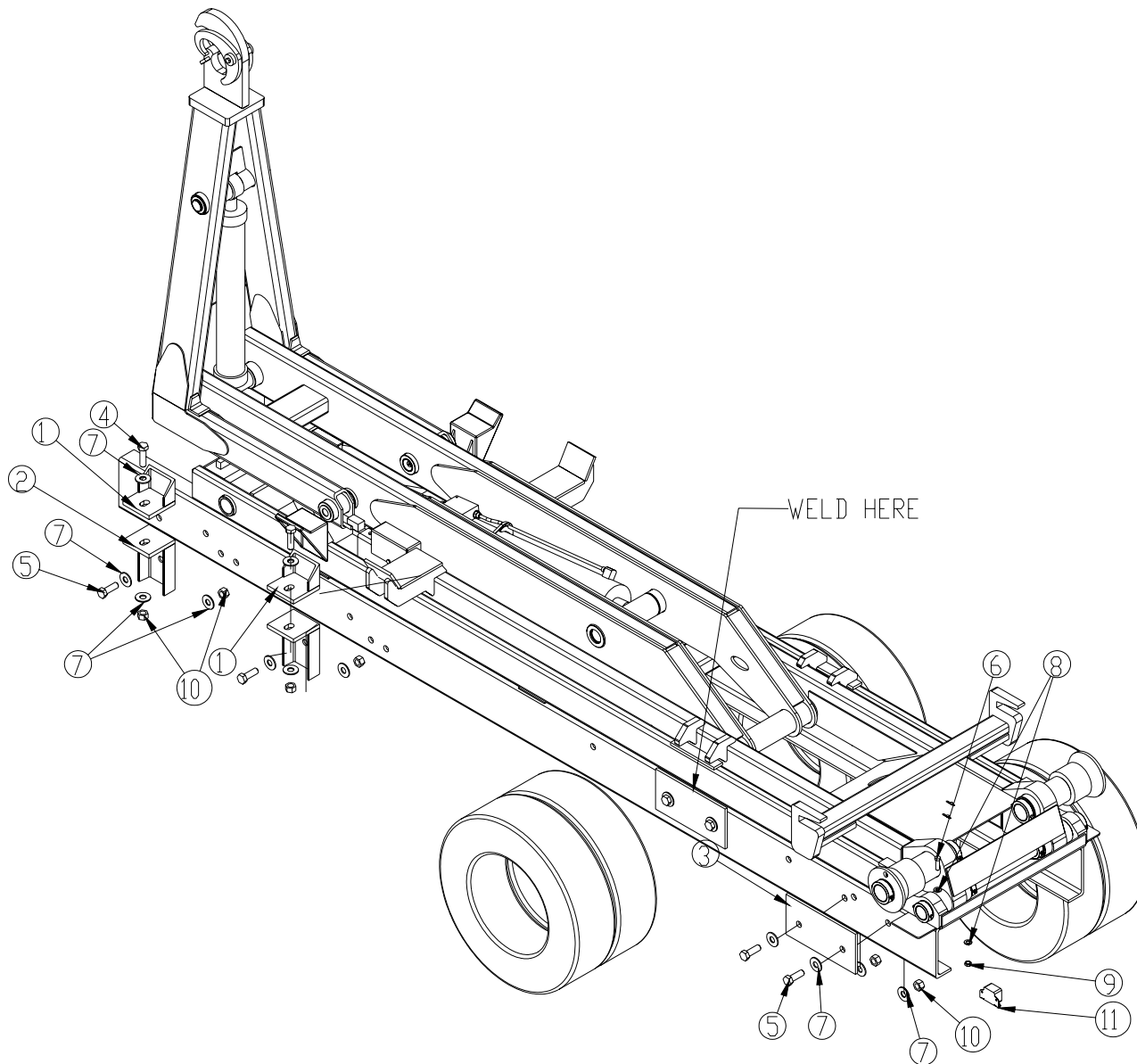

ITEM	PART	DESCRIPTION	QTY.
1	1425	TIE DOWN 40,000#	4
2	1440	TIE DOWN, 40000#	4
3	3596	PLATE 0.50X8.00X16.00	4
4	2830	CAP SCR 1.00-8X3.50 HHGR5	4
5	1442	CAP SCR 1.00-8X3.00 HHGR5	12
6	0399	CAP SCR 0.63-11X2.00 HHGR5	2
7	6538	WASHER 1.00 SAE FLAT GR8	32
8	0358	WASHER 0.63 FLAT SAE	4
9	2826	NUT 0.63-11 HH NYLOC	2
10	0991	NUT 1.00 HH NYLOC	16
11	D0045	BACKUP ALARM .97 DECIBAL	1



# 25 Gallon Hydraulic Assembly P/N 25927

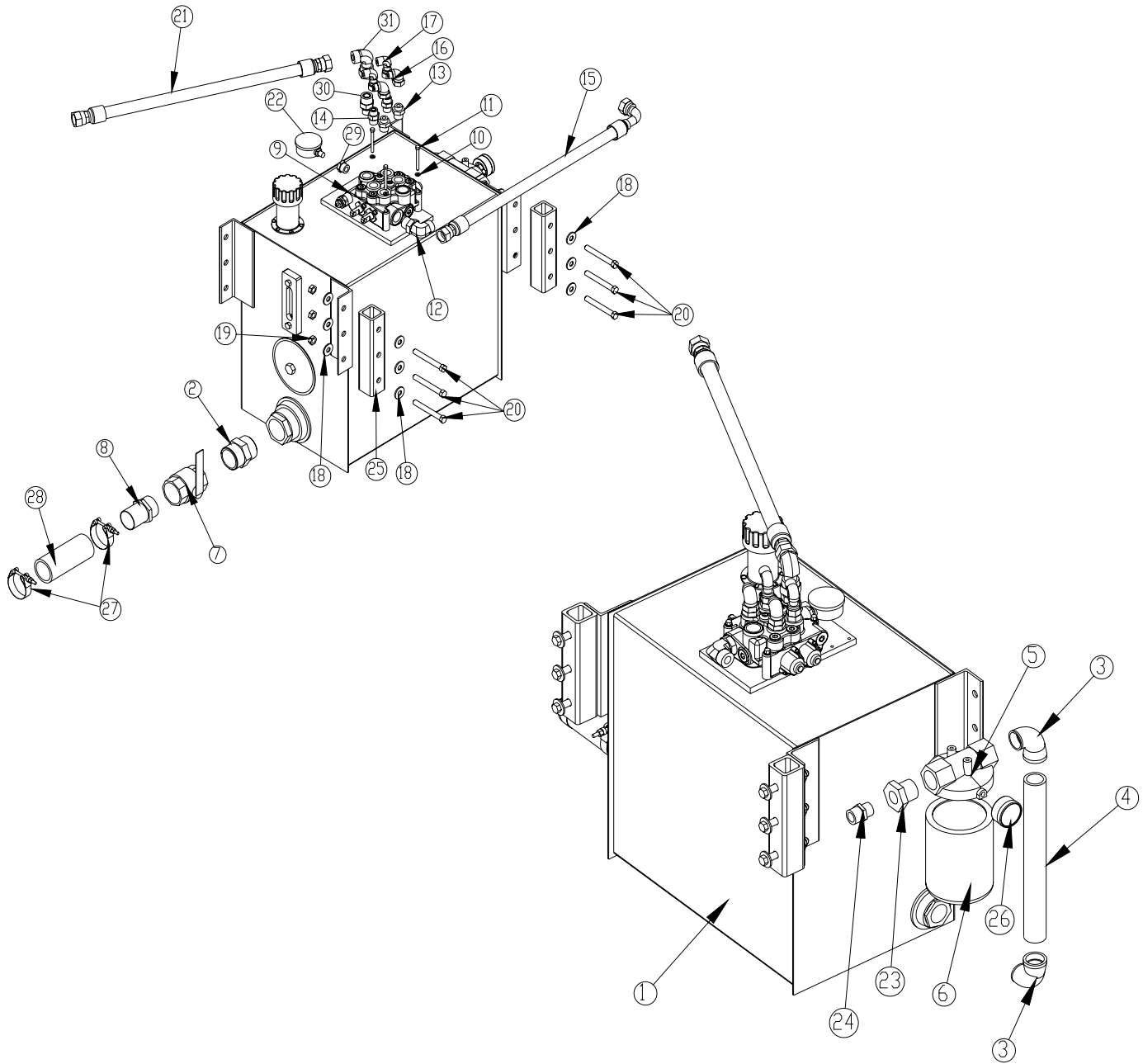

ITEM	PART	DESCRIPTION	QTY.	ITEM	PART	DESCRIPTION	QTY.
1	26510	RSVR ASM 25GAL K MODEL	1	17	C2376	FTG ADAPT 8-C6LO-S	2
2	7353	NIPPLE 2.00 HEX PIPE 2FF	1	18	0352	WASHER 0.50 USS FLAT ZINC	12
3	C4694	ST EL 1.25 90 DEG BLK	2	19	C6106	NUT 0.50-13 HHGR5 NYLOC	6
4	D0024	NIPPLE 1.25X14.00 BLK	1	20	0506	CAP SCR 0.50-13X4.00 HHGR5	6
5	C6228	FILTER HEAD SF120-25 1.3	1	21	27119	HOSE 0.75(78C-12-JC-JC-12-12-120)	1
6	C6225	FILTER LARGE SE-10	1	22	10094	GAUGE OIL LF 2.5" 0-500 BM	1
7	C4750	VALVE BALL 2.00	1	23	C2375	FTG REDU 0102-20-12	1
8	C4730	FTG HOSE BARB 2.00	1	24	C4952	FTG ADAPT 12 FLO-S	1
9	24611	VB 2-SECTION VDM8	1	25	13325	SPACER TANK MOUNTING 25 GAL	2
10	0521	WASHER 0.25 LOCK	3	26	16145	GAUGE PRES FILTER SERVICE CI20	1
11	0339	CAP SCR 0.25-20X2.50 HHGR5	3	27	C4819	HOSE CLAMP 2.00	2
12	C5968	FTG MF/MSTR 90 8-12 C5OLO-S	1	28	17766	HOSE SUCT 2.00 10FT	1
13	C1855	FTG ADAPT 6-10 F5OLO-S	2	29	25630	FTG ADAPT 10-1/4 F5QG	1
14	C2252	FTG ADAPT 8-10-F5OLO-S	2	30	d1435	FTG ADAPT O'RING 12-10	1
15	26737	HOSE 0.75(381-JC-J9-8-8-8-24)	1	31	c4903	FTG SL LOK SWIVEL 12-C6LO-S	1
16	C2248	FTG ADAPT 6-C6LO-S	2				

## 25 Gallon Tank Assembly P/N 26510

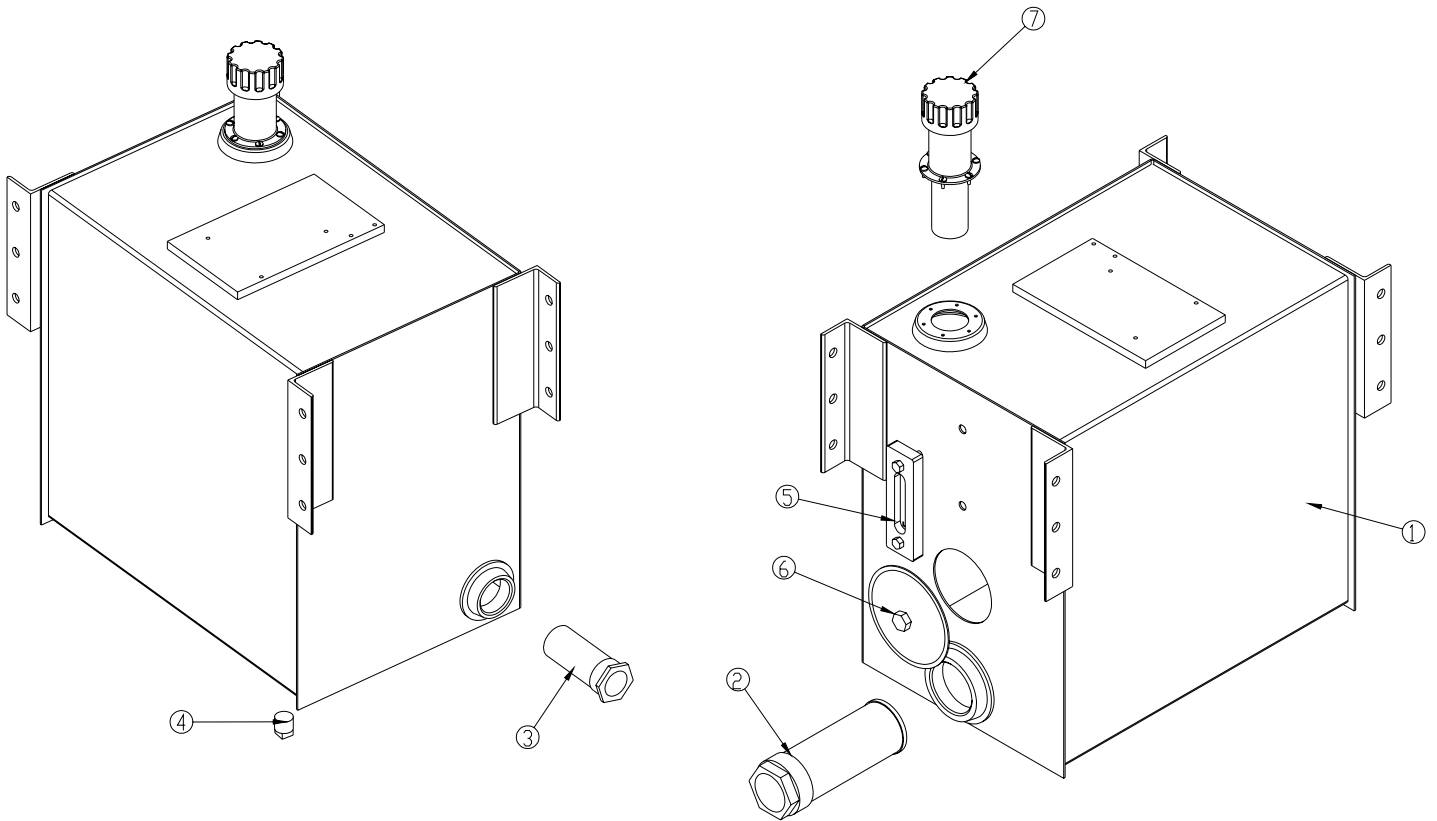

ITEM	PART	DESCRIPTION	QTY.
1	26546	RSRVR 25GAL K MODEL	1
2	C6327	FILTER STRAINER 35GAL TF-2030	1
3	C6328	DIFFUSER 25-35GAL	1
4	C2126	MAGNETIC PLUG DRAIN 3/4"	1
5	15463	THERMO SIGHT GAUGE	1
6	15464	TANK COVER	1
7	15462	CAP FILL ASM W/3" NECK	1

# Hose Kit P/N 17017

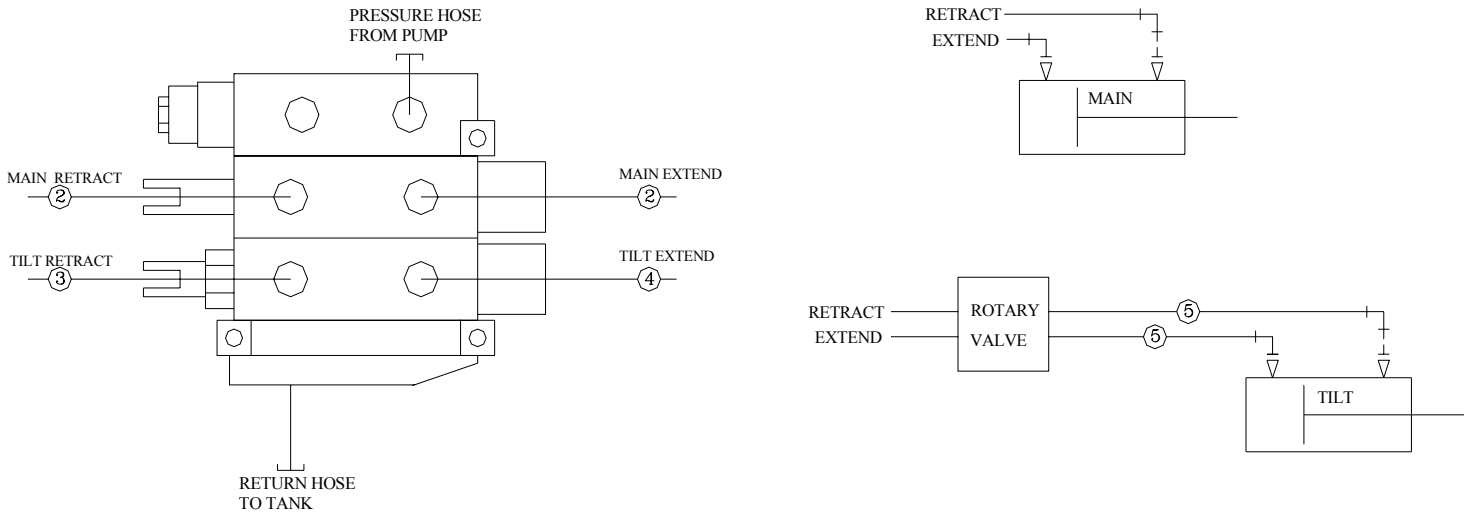

NOTE: IF RESERVOIR IS MOUNTED ON CS, HOSES 3 AND 4 ARE REVERSED

ITEM	PART	DESCRIPTION	QTY.
1	17017	HOSE KIT 138-18-40(ITEMS 2-5)	1
2	16525	HOSE 0.50X74.00	2ref
3	15811	HOSE 0.38X228.00	1ref
4	17019	HOSE 0.38X214.00	1ref
5	17018	HOSE 0.38X178.00	2ref

# Controller Assembly P/N 26414

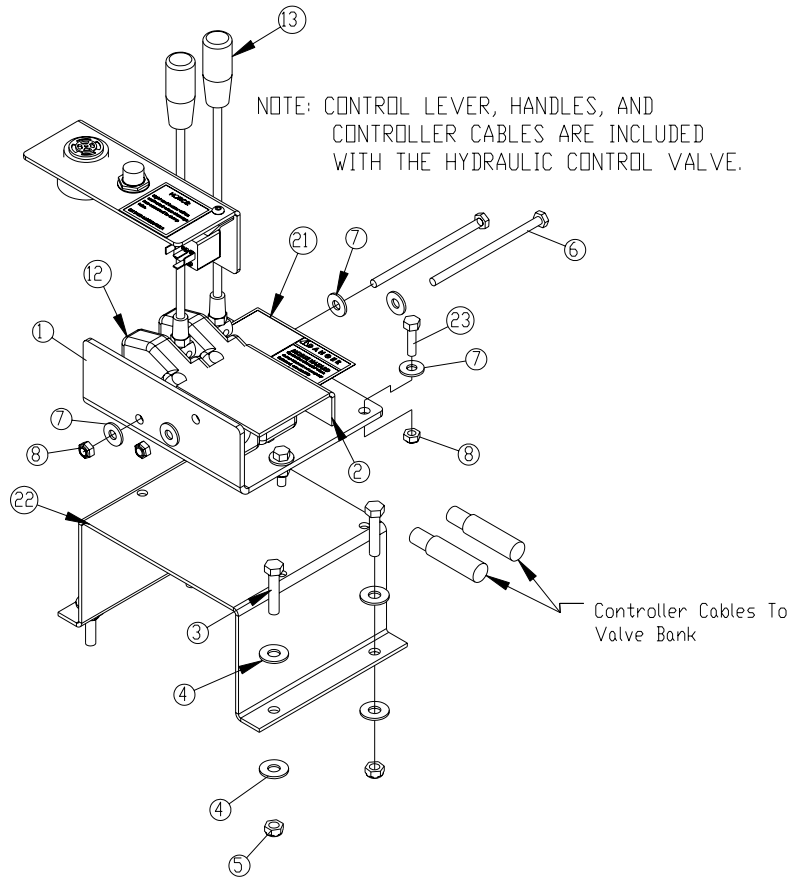

## In Cab Installation

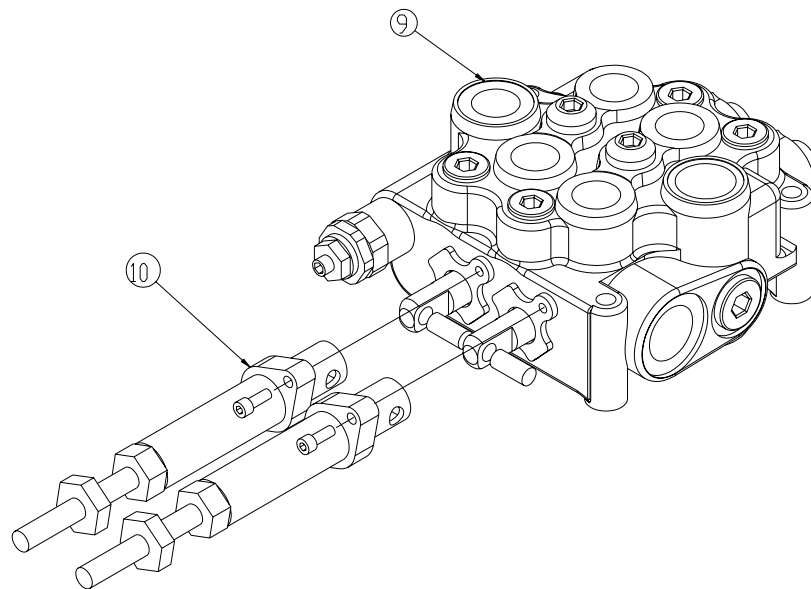

## At Valve Installation

# Controller Assembly Continued

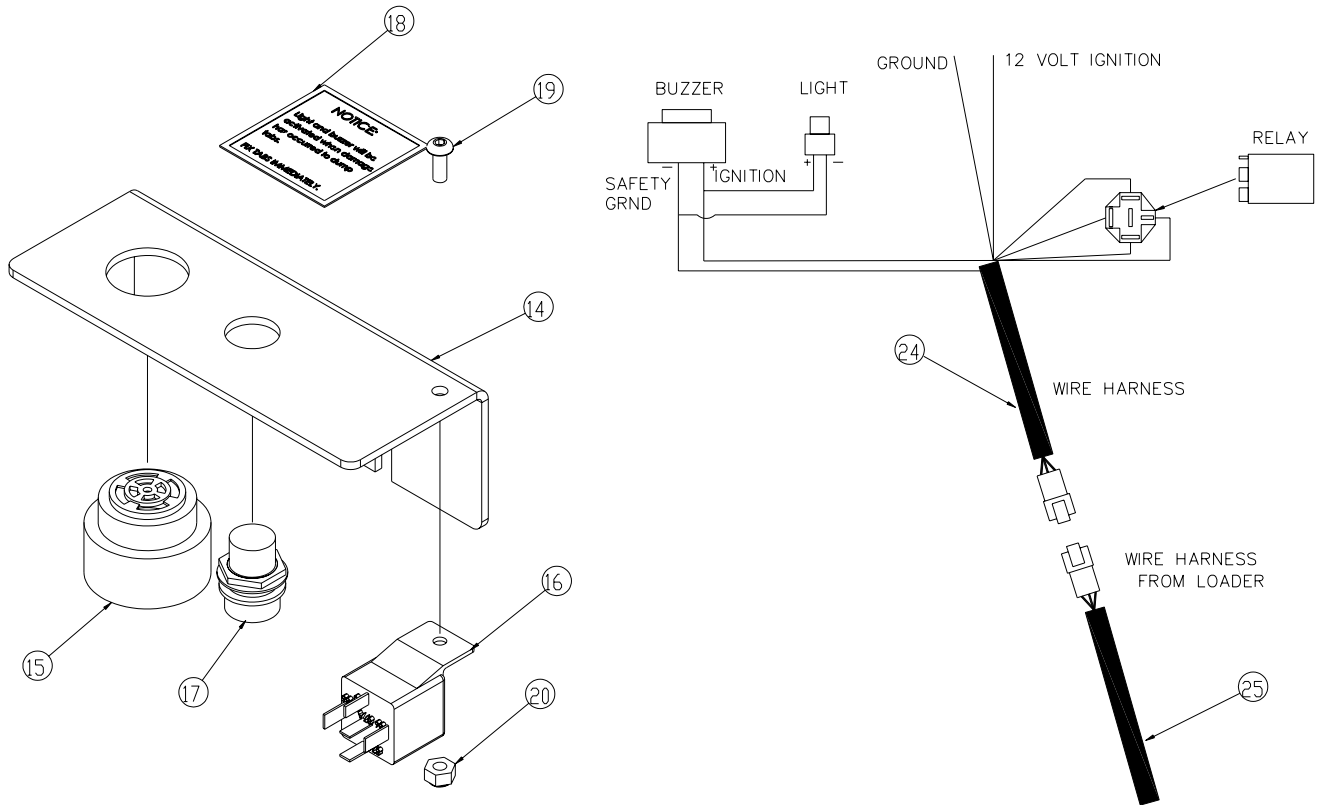

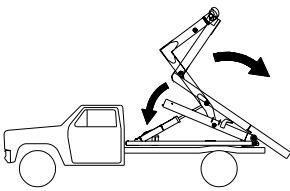

**! DANGER**

**MISUSE HAZARD**  
 Operation of loader when dump tabs are not properly fastened, can result in unexpected personal and equipment damage. Inspect tabs daily.

26134

### Installation Instructions:

Connect the 12 Volt ignition wire to a key-on battery source.  
 Hookup the wire harness in the cab to the wire harness from the loader  
 Alarm will now sound when dump tabs have been damaged.

### Tab Alarm Installation IS Required

ITEM	PART	DESCRIPTION	QTY.	ITEM	PART	DESCRIPTION	QTY.
1	25932	PLATE CONTROLLER MNT	1	14	26293	PLATE TAB ALARM MNT	1
2	25933	BRKT CONTROLLER DECAL	1	15	26031	BACKUP ALARM PIEZO JAMECO 123537	1
3	0486	CAP SCR 0.31-18X1.50 HHGR5	4	16	C6072	RELAY BOSCH 20-30 AMP	1
4	0343	WASHER 0.31 USS FLAT ZINC	8	17	26288	LIGHT INDICATOR RED FORCE PTO	1
5	0342	NUT 0.31-18 HH NYLOC	4	18	26135	DECAL NOTICE FIX TABS	1
6	0528	CAP SCR 0.25-20X4.50 HHGR5	2	19	D1711	CAP SCR #10-24X0.50 BTNHD SS	1
7	0340	WASHER 0.25 FLAT	8	20	26034	NUT #10-24 HH NYLOC	1
8	0333	NUT 0.25-20 HHGR5 NYLOC	6	21	26134	DECAL MISUSE HAZARD	1
9	24611	VB 2-SECTION VDM8	1	22	18801	RISER AIR CONTROL	1
10	24620	CABLE HOOK UP KIT SALAMI	2	23	0480	CAP SCR 0.25-20X1.00 HHGR5	4
11	25935	CONTROL CABLE 16' SALAMI	1	24	26291	WIRE HARNESS TAB ALARM	1
12	24746	CONTROL LEVER SALAMI	2	25	26416	WIRE HARNESS PROXIMITY SWITCH 35FT	1
13	31512	HANDLE CONTROL LEVER SALAMI	2				

## Decal Placement P/N D0779

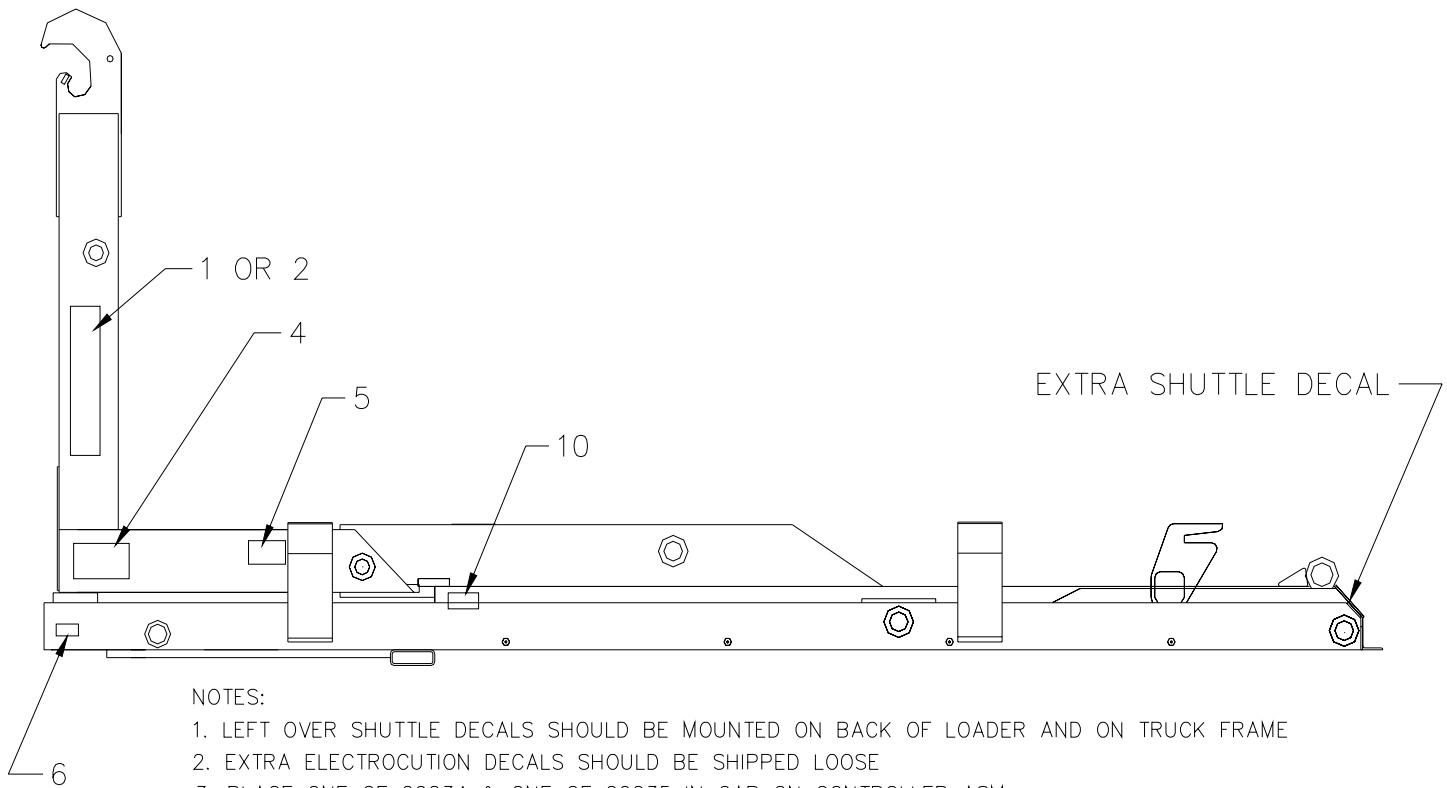

**NOTES:**

1. LEFT OVER SHUTTLE DECALS SHOULD BE MOUNTED ON BACK OF LOADER AND ON TRUCK FRAME
2. EXTRA ELECTROCUTION DECALS SHOULD BE SHIPPED LOOSE
3. PLACE ONE OF 26234 & ONE OF 26235 IN CAB ON CONTROLLER ASM
4. REPLACE SAFETY DECALS IF THEY BECOME WORN

\* THESE DECALS NOT SHOWN(MOUNT IN CAB OR ON TRUCK FRAME)

ITEM	PART	DESCRIPTION	QTY.
1	C6208	DECAL SHUTTLE LARGE	2
2	C6207	DECAL SHUTTLE SMALL	2
*3	C4545	DECAL DANGER ELECTROCUTION	1
4	C1179	DECAL DANGER ELECTROCUTION HORTL	2
5	C0865	DECAL WARNING ARMS	2
6	4214	DECAL CONTACT STELLAR	1
*7	0651	DECAL OPERATION	1
*8	4190	DECAL DANGER OPERATION CONDITION	2
*9	C4540	DECAL DANGER	2
10	26134	DECAL DANGER MISUSE HAZARD	4
*11	26135	DECAL NOTICE FIX TABS	1

# Subframe

Minimum recommended rail construction per number of rear rollers on loader.		
	Single	Double
130-16-40	6x3x3/8 & 1/2x3 Plt	6x3x3/8 & 1/2x3 Plt

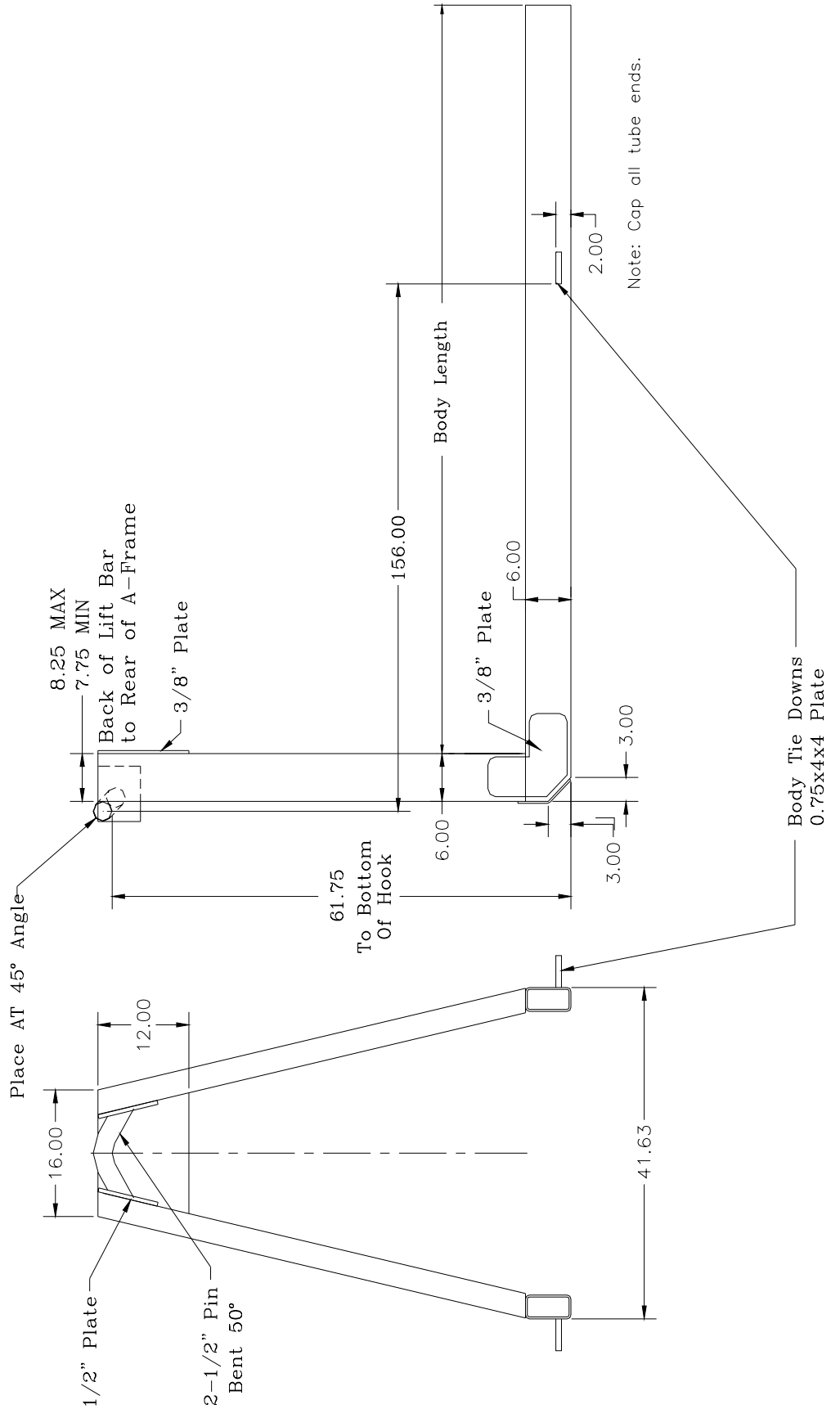



### Limited Warranty Statement

Stellar Industries, Inc. (Stellar) warrants products designed and manufactured by Stellar to be free from defects in material and workmanship under proper use and maintenance. Products must be installed and operated in accordance with Stellar's written instructions and capacities. The warranty period shall cover the following:

Twelve (12) month warranty on parts from the date recorded by Stellar as the in-service date, not to extend beyond twenty-four (24) months from date of manufacture,

Twelve (12) month repair labor from the date recorded by Stellar as the in-service date, not to extend beyond twenty-four (24) month from date of manufacture, and

Thirty-six (36) month warranty on all Stellar Crane and Hooklift structural parts from the date recorded by Stellar as the in-service date, not to extend beyond forty-eight (48) months from date of manufacture.

The in-service date will be derived from the completed warranty registration card. In the event a warranty registration card is not received by Stellar, the factory ship date will be used.

Stellar's obligation under this warranty is limited to, and the sole remedy for any such defect shall be, the repair and/or replacement (at Stellar's option) of the unaltered part and/or component in question. Stellar after-sales service personnel must be notified by telephone, fax, or letter of any warranty-applicable damage within fourteen (14) days of its occurrence. If at all possible, Stellar will ship the replacement part within 24-hours of notification by the most economical, yet expedient, means possible. Expedited freight delivery will be at the expense of the owner.

Warranty claims must be submitted and shall be processed in accordance with Stellar's established warranty claim procedure. Stellar after-sales service personnel must be contacted prior to any warranty claim. A return materials authorization (RMA) account number must be issued to the claiming party prior to the return of any warranty parts. Parts returned without prior authorization will not be recognized for warranty consideration. All damaged parts must be returned to Stellar freight prepaid; freight collect returns will be refused. Freight reimbursement of returned parts will be considered as part of the warranty claim.

Warranty service will be performed by any Stellar new equipment distributor, or by any Stellar-recognized service center authorized to service the type of product involved, or by the Stellar factory in the event of a direct sale. At the time of requesting warranty service, the owner must present evidence of date of delivery of the product. The owner shall be obligated to pay for any overtime labor requested of the servicing company by the owner, any field service call charges, and any towing and/or transportation charges associated with moving the equipment to the designated repair/service provider.

All obligations of Stellar and its authorized dealers and service providers shall be voided if someone other than an authorized Stellar dealer provides other than routine maintenance service without prior written approval from Stellar. In the case repair work is performed on a Stellar-manufactured product, original Stellar parts must be used to keep the warranty in force. The warranty may also be voided if the product is modified or altered in any way not approved, in writing, by Stellar.

The owner/operator is responsible for furnishing proof of the date of original purchase of the Stellar product in question. Warranty registration is the ultimate responsibility of the owner and may be accomplished by the completion and return of the Stellar product registration card provided with the product. If the owner is not sure of registration, he is encouraged to contact Stellar at the address below to confirm registration of the product in question. This warranty covers only defective material and workmanship. It does not cover depreciation or damage caused by normal wear and tear, accident, mishap, untrained operators, or improper or unintended use. The owner has the obligation of performing routine care and maintenance duties as stated in Stellar's written instructions, recommendations, and specifications. Any damage resulting from owner/operator failure to perform such duties shall void the coverage of this warranty. The owner will pay the cost of labor and supplies associated with routine maintenance.

The only remedies the owner has in connection with the breach or performance of any warranty on the Stellar product specified are those set above. In no event will Stellar, the Stellar distributor/dealer, or any company affiliated with Stellar be liable for business interruptions, costs of delay, or for any special, indirect, incidental, or consequential costs or damages. Such costs may include, but are not limited to, loss of time, loss of revenue, loss of use, wages, salaries, commissions, lodging, meals, towing, hydraulic fluid, or any other incidental cost.

All products purchased by Stellar from outside vendors shall be covered by the warranty offered by that respective manufacturer only. Stellar does not participate in, or obligate itself to, any such warranty.

Stellar reserves the right to make changes in design or improvement upon its products without imposing upon itself the same upon its products theretofore manufactured.

This warranty will apply to all Stellar Hooklifts, Stellar Service Trucks, & Truck-mounted Cranes shipped from Stellar's factory after July 1, 2005. The warranty is for the use of the original owner only and is not transferable without prior written permission from Stellar.

THIS WARRANTY IS EXPRESSLY IN LIEU OF ANY OTHER WARRANTIES, EXPRESS OR IMPLIED, INCLUDING ANY WARRANTY OF MERCHANTABILITY OR FITNESS FOR A PARTICULAR PURPOSE. REMEDIES UNDER THIS WARRANTY ARE LIMITED TO THE PROVISION OF MATERIAL AND SERVICES, AS SPECIFIED HEREIN. STELLAR INDUSTRIES, INC. IS NOT RESPONSIBLE FOR INCIDENTAL OR CONSEQUENTIAL DAMAGES.

Revision Date: February 2007

Document Number: 37040